

HOME VENTILATION WITH HEAT RECOVERY

M-WRG-S ventilation unit



OPERATING INSTRUCTIONS

Part no. 5302-00-01 Week 07/2024 EN



Contents

1	Introduction	5
1.1	Notes on the operating instructions	5
1.2	Description	5
1.2.1	Optional accessories	6
1.3	Target group	6
1.4	EU declaration of conformity	6
1.5	National technical approval (for Germany)	7
1.6	Nameplate	7
1.7	Technical data	8
1.7.1	Electrical connection	8
1.7.2	Dimensions and weight	8
1.7.3	Noise emission	8
1.7.4	Ambient conditions	8
1.7.5	Unit properties	9
1.7.6	Unit features	9
1.7.7	Air filters	9
1.8	Environmentally-friendly disposal	10
1.9	Revision index	10
1.10	Explanation of the symbols used	10
1.11	Supplementary documents	10
2	Safety instructions	11
2.1	Hazard classification	11
2.2	Notes on using the ventilation units safely	11
2.2.1	Fire protection	11
2.2.2	Operation with fireplaces	11
2.2.3	Installation in wet areas	12
2.2.4	Build-up of icicles and ice patches at low temperatures	12
2.2.5	Starting and using the ventilation unit	12
2.3	Notes on using the ventilation units	12
2.4	Note on use in conjunction with room air conditioners	13
2.5	Intended use	13
3	Warranty and liability	14
3.1	Warranty	14
3.2	Liability	14
4	Dimensions	15
5	Structure and function	16
5.1	Overview of the modules	16
5.1.1	Ventilation unit – unit cover attached	16
5.1.2	Ventilation unit – unit cover removed	16
5.2	Description of the functions	17
5.2.1	How the M-WRG ventilation unit works	17
5.2.2	How the cross-flow plate heat exchanger works	18

6	Rules for correct usage	18
6.1	General	18
6.2	Operation at cold times of year	19
6.3	Summer mode	19
6.4	Air filters	20
7	Controls on the ventilation unit	20
8	Starting up	21
8.1	Checking the ventilation unit before switching on for the first time	21
8.2	Switching on the ventilation unit	21
8.3	Check position of air flaps	21
9	Operating the ventilation unit	22
9.1	Setting the ventilation level/program on the step switch	22
9.2	Frost protection function	22
10	Ventilation levels/programs	23
10.1	“Reduced ventilation (people absent)”	23
10.2	“Normal ventilation (people present)”	23
10.3	“Increased ventilation”	23
10.4	“Intensive ventilation (temporary 15 min)”	23
11	Options for ventilation mode	23
11.1	External control input	23
11.1.1	Description	23
11.1.2	Factory defaults and possible adjustment ranges	24
11.1.3	M-WRG-O/EST-1, part no. 5046-31, and M-WRG-O/EST-2, part no. 5046-32	24
11.2	Parameter settings for special air outputs for all M-WRG units, M-WRG-O/PARM, part no. 5046-00	24
11.3	Minimum ventilation to DIN 18017-3, M-WRG-O/MVS, part no. 5046-11	24
11.4	Mains switch without function, M-WRG-O/NOF, part no. 5046-10	24
11.5	Allergy filter replacement, M-WRG-O/Filter-FA, part no. 5046-50	24
12	Filter maintenance	25
12.1	Choice of filter	25
12.2	Ordering filters	25
12.3	Changing the air filters	26
12.3.1	Removing the unit cover from the ventilation unit	26
12.3.2	Remove air filters	26
12.3.3	Insert new air filters	27
12.3.4	Attaching the unit cover to the ventilation unit and switching on the ventilation unit	28
12.3.5	Resetting the filter change indicator	28
13	Cleaning and maintenance	29
14	Troubleshooting	30



1 Introduction

1.1 Notes on the operating instructions



These original operating instructions contain important information that should be followed when setting up and using the M-WRG-S ventilation unit.

- ▶ Read all the instructions carefully before starting up the ventilation unit to avoid possible risks and mistakes.
- ▶ When assembly is complete, give these instructions to the home owner, caretaker or property manager.
- ▶ These instructions are part of the product. Keep the instructions in a safe place for future reference.

! WARNING

- ▶ Follow ALL danger and warning instructions and notes on precautionary measures.
- ▶ Read section “2 Safety instructions” on page 11 carefully.

1.2 Description

These instructions describe how to set up and operate the decentralised ventilation unit M-WRG-S (see Fig. 1).

M-WRG stands for Meltem heat recovery. Home ventilation expertise extending back over 40 years has been incorporated into this product from Meltem Wärmerückgewinnung.

Using windows for ventilation, particularly during periods of cold weather, is now a thing of the past. This ventilation unit brings in outdoor air fully automatically, and heats it by recovering heat from the air that is extracted. Outdoor air and extract air are routed in separate ducts through a cross-flow plate heat exchanger (see section 5.2.2 on page 18). You save on heating costs, increase your living comfort and are kind to the environment by reducing CO₂ emissions. An air filter from dust class PM10 also cleans the outdoor air (e.g. pollen). There is also an optional allergy filter from dust class PM1 available.

The ventilation units are designed to run continuously and can be equipped with optional sensors (e.g. external wireless humidity / CO₂ sensor) for on-demand ventilation. They can be surface-mounted, flush-mounted or integrated into the wall (U²). The ventilation units are low-maintenance, but **regular air filter changes** are important.



Fig. 1: M-WRG-S ventilation unit

On the M-WRG-S ventilation unit, a step switch can be used to set four different ventilation levels/programs; the maximum ventilation level is activated using a switching sequence and is time-limited.

1.2.1 Optional accessories

Part no.	Type	Description
5453-00	M-WRG-GW	The M-WRG-S ventilation units can be controlled, programmed and the range of functions extended using an app via the gateway. It can also be used to read the number of operating hours.
5478-10	M-WRG-FBH	The wireless remote control is used to control, program and extend the range of functions of the M-WRG-S units. It can also be used to read the number of operating hours.
5478-20	M-WRG-FT	The 4-way wireless pushbutton switch with LED feedback allows the M-WRG-S units to be operated wirelessly.
733010	M-WRG-II FSF	The external wireless humidity sensor is a control unit with 5 ventilation levels/programs including humidity sensor for on-demand operation of the M-WRG-S ventilation units. Allows the sensor to be positioned flexibly within the room or can be retrofitted for units without sensors (battery-operated).
733011	M-WRG-II FSC	The external wireless CO ₂ sensor is a control unit with 5 ventilation levels/programs including CO ₂ sensor for on-demand operation of the M-WRG-S ventilation units. Allows the sensor to be positioned flexibly within the room or can be retrofitted for units without sensors (230 V connection required).

Table 1: Optional accessories

1.3 Target group

These operating instructions are intended for users of the ventilation unit. No special prior knowledge is needed.

1.4 EU declaration of conformity

The M-WRG-S... ventilation units manufactured by
Meltem Wärmerückgewinnung GmbH & Co. KG
Am Hartholz 4
82239 Alling

conform to the regulations and standards listed in the EU Declaration of Conformity provided.

1.5 National technical approval (for Germany)

A valid national technical approval from the Deutsches Institut für Bautechnik (DIBt) must be obtained for the ventilation unit before it is installed in Germany. This approval can be provided upon request or can be downloaded from our website at www.meltem.com/service/downloads/ (see also the QR code on the back page of these instructions).

The approval number is Z-51.3-138 (see item 1 in Fig. 3).

- For installation outside Germany, the national regulations applicable in your country should be followed.

1.6 Nameplate

Meltem Wärmerückgewinnung GmbH & Co. KG Am Hartholz 4 82239 Alling www.meltem.com Tel.: 08141-40 41 79-0			
Device no.:	Type: M-WRG-S		
	Part no.: 5010		
	max. 37 W		
	230 V	50 Hz	IPX1
			Iso-Kl. B

Fig. 2: Nameplate

You will find the nameplate on the intermediate plate on the inside of the housing (see item 2 in Fig. 3).



Fig. 3: Position of approval number and nameplate

1.7 Technical data

1.7.1 Electrical connection

Operating voltage	230 V AC (working voltage range: 85 V AC to 265 V AC)
Mains frequency	50 to 60 Hz
Power consumption	2.5 to 37 W
Standby power consumption	approx. 1 W
Maximum current consumption	0.16 A
IP code	— IPX1 — IPX4 with protective cap on mains switch (optional, must be installed at the factory) — IPX5 with Integrated into wall U ² installation version
Energy efficiency class (ErP)	B/A*

* In combination with the external wireless humidity or CO₂ sensors

1.7.2 Dimensions and weight

Unit dimensions excluding air connectors (see also Fig. 4 on page 15)	388 x 409 x 196 (W x H x D)
Visible unit depth when surface-mounted	196 mm
Visible unit depth when flush-mounted	66 mm
Visible unit depth when integrated into wall	-
Outdoor air/exhaust air connectors	DN 100
Weight	Approx. 7.3 kg

1.7.3 Noise emission

Sound pressure level L _{P,A} surface-mount	19.0 to 46 dB(A)/A _{eq} 10 m ²
Sound pressure level L _{P,A} flush-mount	15.5 to 46.5 dB(A)/A _{eq} 10 m ²
Sound pressure level L _{P,A} integrated into wall U ² with ductwork connection on extract air side	12.4 to 41.9 dB(A)/A _{eq} 10 m ²
Sound insulation D _{n,e,w} unit in use depending on installation version	50 to 56 dB

1.7.4 Ambient conditions

Storage temperature range (in the original packaging in a dry place)	0 °C to +40 °C
Permitted temperature range of outdoor air during operation at a room temperature of at least 20 °C	-22 °C to +40 °C
Permitted ambient air humidity during operation	up to approx. 70 % RH

1.7.5 Unit properties

Type of system	Decentralised, heat recuperation
Air flow	15 to 97 m ³ /h
Heat recovery efficiency (max.), η_0 , DIN EN 13141-8	71 %
Colour	White similar to RAL 9010
TÜV-tested	Yes
Hygiene tested for conformity with VDI 6022 sheet 1	W-377516-23-Zd*
National technical approval (DIBt)	Z-51.3-138

* With the optional outdoor air filter ISO ePM1 60% (F7)

1.7.6 Unit features

Output control	4-level on the unit, 10-level with accessories
Supply air / exhaust air fan	EC direct current radial fan
Heat exchanger	Cross-flow plate heat exchanger
Filter monitoring with filter change indicator	Time-dependent, audible
Condensate drain	Via exhaust air pipe/outer wall terminal or condensate connection provided by the customer
Fully automatic cover flap control when switching On / Off, in Standby mode and if the power fails	Yes
Frost protection function	Yes
Operating hours display	Using optional accessories (see section 1.2.1 on page 6)
Humidity control	Optional with accessories (see section 1.2.1 on page 6)
CO ₂ control	Optional with accessories (see section 1.2.1 on page 6)
Automatic mode (humidity and CO ₂ control)*	Optional with accessories (see section 1.2.1 on page 6)
Filter type	Round filter cartridges for outdoor air and extract air

* Requirement: Both external wireless sensors (humidity and CO₂) must be logged into the ventilation unit.

1.7.7 Air filters

Designation	Filter class
Standard filter (for outdoor air and extract air)	ISO ePM10 65% (G4)
Allergy filter (optional, for outdoor air only)	ISO ePM1 60% (F7)
Activated charcoal filter (optional, for outdoor air only)	ISO ePM10 60% (M6)

1.8 Environmentally-friendly disposal

Avoiding waste from electrical and electronic devices makes a significant contribution to environmental protection and the better use of resources. Recycling and other ways of reusing such waste also reduce the amount of waste that needs to be taken away.



- ▶ You should dispose of the product in accordance with your applicable national regulations.

1.9 Revision index

Edition	Manual	Date
9 th edition	Operating instructions for M-WRG-S ventilation unit	Week 07/2024 EN

1.10 Explanation of the symbols used

- ▶ This symbol indicates an action to be taken.
- This symbol indicates a list.

1.11 Supplementary documents

Manual	Part no.
Installation manual for M-WRG-S... ventilation units	5253-01
Maintenance instructions for M-WRG-S... ventilation units	5303-00-01
User guide for M-WRG-FBH wireless remote control	5302-25-01
Installation instructions and user guide for 4-way wireless pushbutton switch	5301-14-01
Installation instructions and user guide for external wireless humidity sensor	744011EN
Installation instructions and user guide for external wireless CO ₂ sensor	744012EN
Installation instructions and user guide for gateway	744013EN
App user guide	744014EN

Table 2: Supplementary documents

You will find further manuals and instructions on our website at www.meltem.com/service/downloads/ (or using the QR code on this page).



Go to
Meltem download area

2 Safety instructions

These instructions contain notes that you must follow for your own personal safety and to avoid injury and damage to property. They are highlighted by warning triangles and are shown as follows according to the level of danger.

2.1 Hazard classification

DANGER

The signal word designates a hazard with a **high** degree of risk which, if it is not avoided, will result in death or severe injury.

WARNING

The signal word designates a hazard with a **medium** degree of risk which, if it is not avoided, will result in death or severe injury.

CAUTION

The signal word designates a hazard with a **low** degree of risk which, if it is not avoided, could result in minor or moderate injury.

NOTICE

A note as used in this manual contains important information about the product or about a part of the manual to which particular attention should be paid.

2.2 Notes on using the ventilation units safely

2.2.1 Fire protection

Follow the generally applicable fire safety requirements when planning and installing the unit.

2.2.2 Operation with fireplaces

- When M-WRG ventilation units are used in conjunction with fireplaces, an additional safety device (underpressure or differential pressure monitor) is needed to monitor operation and to switch off the (230 V) power supply to the units when necessary.
- Follow the requirements of the German Fire Code (FeuVo) when planning and installing the unit.
- Contact the local chimney sweep before the end of the planning phase.
- Have the chimney sweep approve the operation of the ventilation unit.
- Correct use of a ventilation system set up with the decentralised ventilation unit requires the possibility of shutting off combustion air pipes and flue systems for solid fuel fireplaces during periods in which the fireplaces are not in use.

2.2.3 Installation in wet areas

The following rules from DIN VDE 0100-701/702 (IEC 60364-7-701) apply to installation of M-WRG ventilation units in wet areas:

- Protection zone 0: The unit must NOT be installed in this area.
- Protection zone 1: The unit must only be installed with the “integrated into wall” U² variant. The extract and supply air valves must be installed in the top part of the wall or in the ceiling.
- Protection zone 2: The unit may be installed in this area if the mains switch is covered with a protective cap. The protective cap must be installed at the factory.
 - ▶ You will need to include the mains switch protective cap (M-WRG-SN, part no. 5430) when you order the ventilation unit.
- Other zone: The unit may be installed in this area.

Country-specific standards/regulations on observing the protection zones for installation in rooms with bathtub or shower must also be followed.

2.2.4 Build-up of icicles and ice patches at low temperatures

The heat recovery process in our ventilation units causes condensation. This condensation is dissipated to the outside via the exhaust air pipe. When external temperatures drop below 0 °C this can cause a build-up of icicles at the outer wall terminals and ice patches on the ground.

For this reason, the position of the units and arrangement of the outer wall terminals should be selected to eliminate any risk to people and property.

If such risks cannot be excluded, a condensate connection should be provided (see associated installation manual).

2.2.5 Starting and using the ventilation unit

- Do not start up the ventilation unit until it is fully installed.
- Always operate the ventilation unit with the air filters fitted.
- Always make sure that the cover is closed and locked in place before using the ventilation unit.
- Please note that the ventilation unit must not be used without the outer wall terminal for safety reasons.

2.3 Notes on using the ventilation units

- This unit may be used by children from 8 years old and by persons of restricted physical, sensory or mental abilities or persons lacking experience and knowledge if they are supervised or have been instructed in how to use the unit safely and understand the associated hazards. Do not allow children to play with the unit. Cleaning and user maintenance must not be carried out by children unless they are supervised.
 - ▶ Follow the regulations applicable in your country concerning the age from which people may be permitted to operate the ventilation unit.

- The ventilation unit must always be freely accessible for operation and maintenance.
 - ▶ Make sure that the ventilation unit is not covered or obstructed when the room is subsequently decorated and furnished, otherwise it cannot be operated and it will not be possible to replace the air filters. You should therefore maintain a clearance of at least 15 cm in front of the ventilation unit cover.
 - ▶ Make sure that the supply and extract air openings are not covered when the room is subsequently decorated and furnished, otherwise the ventilation unit's functions may be impaired.

2.4 Note on use in conjunction with room air conditioners

Condensation may form in the ventilation unit if the outdoor air temperature and humidity are high, but the room temperature is cool.

For the M-WRG ventilation units, the room temperature should therefore be set to no more than 8 °C below the external temperature.

M-WRG ventilation units and room air conditioners can be combined very well.

2.5 Intended use

- The ventilation unit is designed to ventilate living spaces and rooms used for quasi-residential purposes. It can also be installed in offices, surgeries, etc. The ventilation unit is installed in a perpendicular position in the external wall. Any different or more extensive usage will be regarded as contrary to the intended use.
- The intended use also includes compliance with all the notes in the operating instructions.
- The ventilation unit must not be operated without air filters or outer wall terminal.
- The ventilation unit is intended for use in rooms with normal room air humidity levels of approx. 40 % to 70 % RH. It must not be installed in rooms in which the relative humidity during operation constantly exceeds 80 %.
- The ventilation unit's functions may be impaired or the unit may be damaged in rooms with a lot of dust (e.g. model-making) or corrosive gas emissions (e.g. blueprint shop, cleaning).
- For any use contrary to the intended use, Meltem Wärmerückgewinnung GmbH & Co. KG shall accept no liability for any damage that may occur and offers no warranty that the ventilation unit will work perfectly and correctly.

3 Warranty and liability

3.1 Warranty

The following cases shall invalidate the warranty:

- The installation kit was not installed as described in the installation manual.
- The ventilation unit was not installed as described in the installation manual.
- The ventilation unit was flush-mounted without using a flush-mount installation kit.
- Genuine parts/genuine air filters were not replaced with genuine parts.
- Unapproved changes were made to the installation kit or ventilation unit.
- Repairs were not carried out by Meltem or by an authorised specialist company.
- The ventilation unit was operated without air filters and outer wall terminals.
- The warranty does not cover wearing parts such as air filters.

3.2 Liability

The manufacturer's liability shall not apply in the following cases:

- The installation kit was not installed as described in the installation manual.
- The ventilation unit was not installed as described in the installation manual.
- The ventilation unit was flush-mounted without using a flush-mount installation kit.
- Genuine parts/genuine air filters were not replaced with genuine parts.
- Unapproved changes were made to the installation kit or ventilation unit.
- Repairs were not carried out by Meltem or by an authorised specialist company.
- The ventilation unit was operated without air filters and outer wall terminals.

4 Dimensions

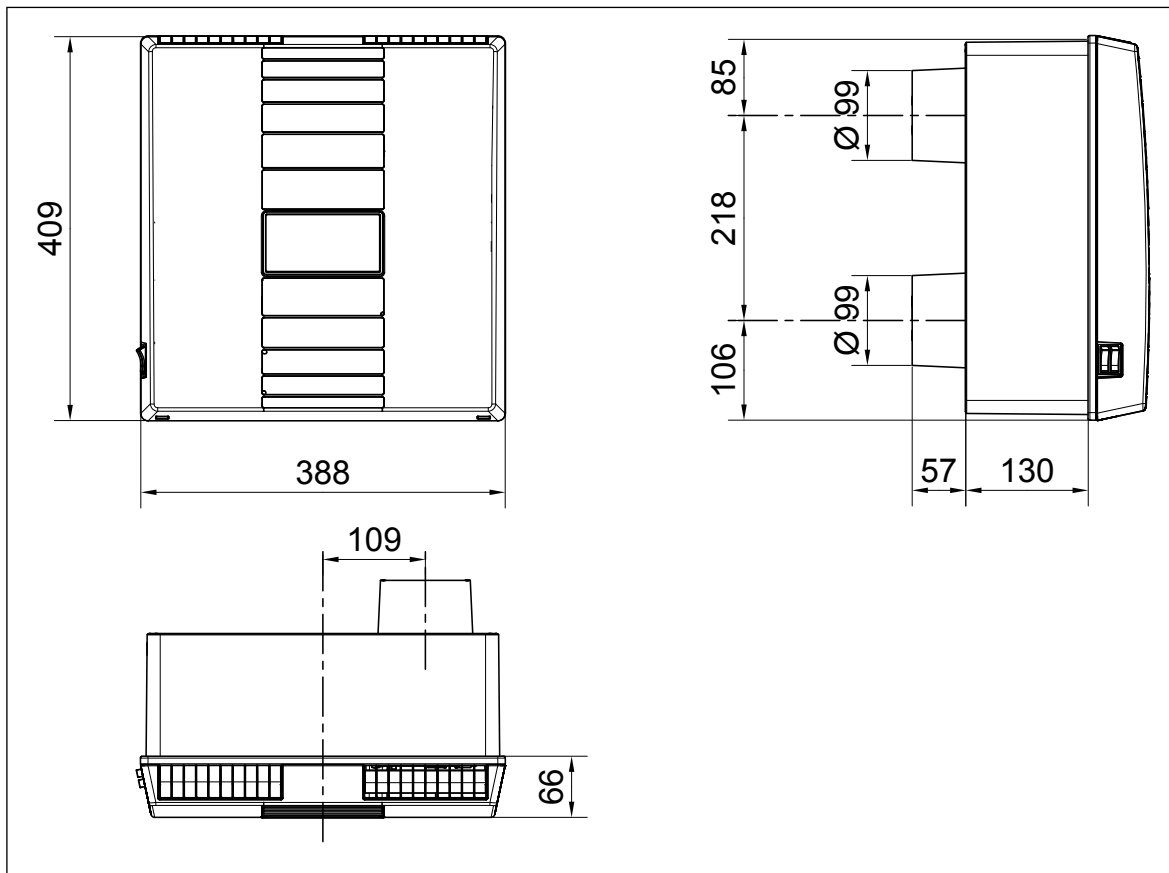

Fig. 4: Dimensions of the M-WRG-S ventilation unit, in millimetres

5 Structure and function

5.1 Overview of the modules

5.1.1 Ventilation unit – unit cover attached

Item in Fig. 5	Designation
1	Housing
2	Unit cover
3	Step switch for four ventilation levels/programs
4	Mains switch "On / Off"

5.1.2 Ventilation unit – unit cover removed

Item in Fig. 6	Designation
1	Supply air opening with air flap
2	Outdoor air filter with filter cover
3	Intermediate plate
4	Network connection cover
5	Supply air hood
6	Extract air filter with filter ring
7	Extract air opening with air flap

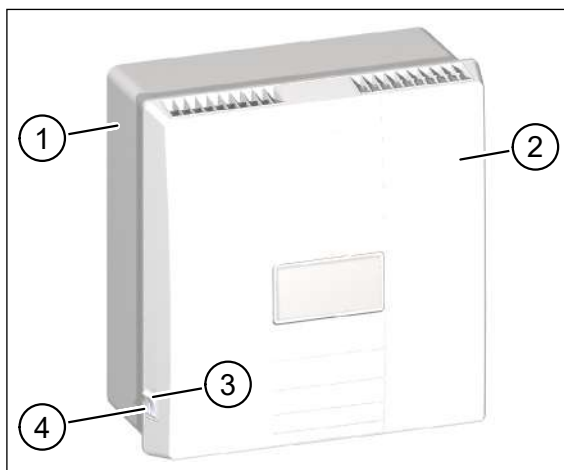

Fig. 5: Ventilation unit – unit cover attached

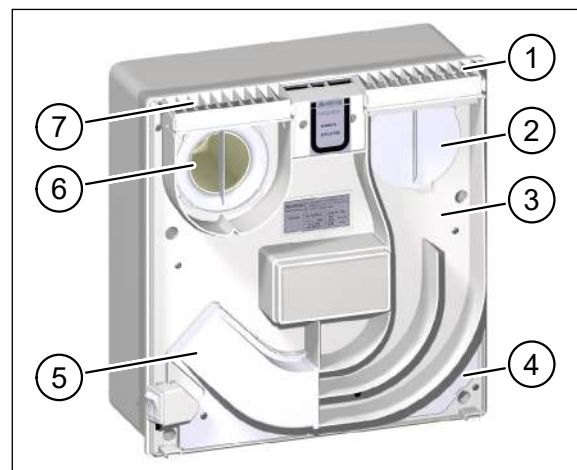

Fig. 6: Ventilation unit – unit cover removed

5.2 Description of the functions

5.2.1 How the M-WRG ventilation unit works

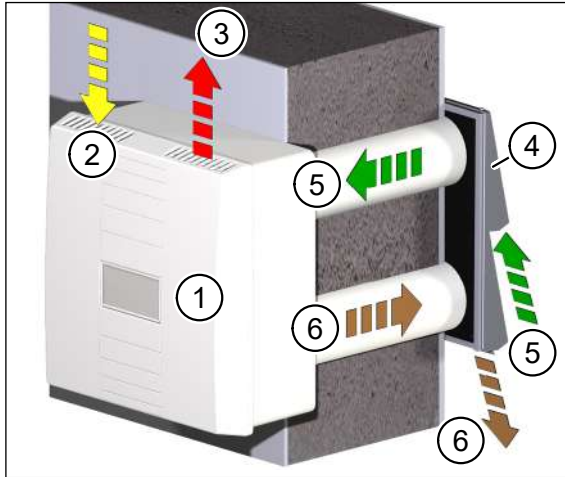

Fig. 7: How the ventilation unit works

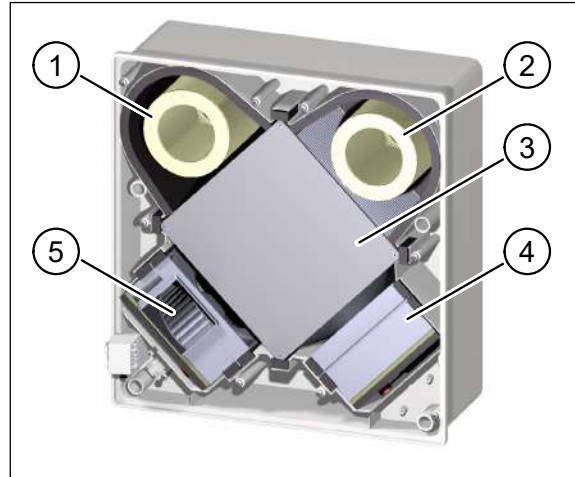

Fig. 8: Components for air exchange

Item in Fig. 7	Designation
1	M-WRG ventilation unit
2	Extract air
3	Supply air
4	Outer wall terminal
5	Outdoor air
6	Exhaust air

Item in Fig. 8	Designation
1	Extract air filter
2	Outdoor air filter
3	Cross-flow plate heat exchanger
4	Exhaust air fan
5	Supply air fan

The ventilation unit operates continuously, transports outdoor air and extract air at the same time and guides and filters the outdoor air and extract air separately.

The fans are arranged on the supply air and exhaust air sides. The supply air fan (item 5 in Fig. 8) transports outdoor air (item 5 in Fig. 7) through the outdoor air filter (item 2 in Fig. 8) and cross-flow plate heat exchanger (item 3 in Fig. 8) into the interior as supply air (item 3 in Fig. 7). The exhaust air fan (item 4 in Fig. 8) extracts the extract air (item 2 in Fig. 7) from the interior. In the extract air filter (item 1 in Fig. 8), the extract air is cleaned, guided through the cross-flow plate heat exchanger and carried outside as exhaust air (item 6 in Fig. 7).

The supply air and exhaust air fans each transport the same volume of air. The pressure in the interior remains practically constant.

5.2.2 How the cross-flow plate heat exchanger works

The warm extract air (item 5 in Fig. 9) drawn in from the interior is routed through the chambers of the cross-flow plate heat exchanger (item 1 in Fig. 9) and heats them.

The cooled extract air is carried to the outside as exhaust air (item 3 in Fig. 9).

At the same time, the cold outdoor air that is drawn in (item 2 in Fig. 9) is routed through the chambers of the cross-flow plate heat exchanger, which are separate from the extract air, and is heated. The separate chambers prevent the outdoor air and extract air from mixing.

The heated outdoor air is routed into the interior as supply air (item 4 in Fig. 9).

Item	Designation
1	Cross-flow plate heat exchanger
2	Outdoor air
3	Exhaust air
4	Supply air
5	Extract air

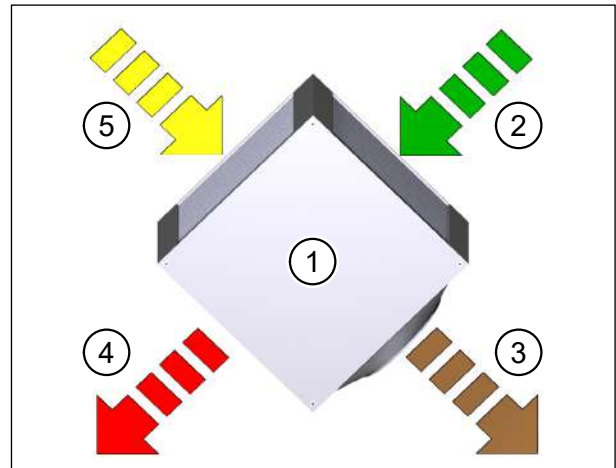

Fig. 9: How the cross-flow plate heat exchanger works

6 Rules for correct usage

6.1 General

- ▶ Always operate the ventilation unit with the unit cover attached.
- ▶ Run the ventilation unit either in continuous mode or on-demand via humidity or CO₂ sensors (e.g. external wireless humidity / CO₂ sensor). While continuous mode constantly ensures a good and healthy atmosphere in the room, on-demand ventilation uses sensors to provide particularly energy-efficient ventilation that is tailored precisely to requirements.
- ▶ Adapt the air flow through the ventilation unit to take account of the air load created by cooking, washing, ironing, visitors, showers, sauna, etc.
- ▶ Set the ventilation unit so that the relative humidity ranges between 40 % and 65 %. People feel most comfortable within this range.

6.2 Operation at cold times of year

- ▶ During cold times of year, run the ventilation unit in continuous mode or on-demand via humidity or CO₂ sensors (e.g. external wireless humidity / CO₂ sensor).
 - Energy-saving motors and an innovative controller ensure a very low power consumption, even in continuous mode.
 - Continuous removal of moisture from the interior is only guaranteed while the unit is in operation.
- ▶ Run the intensive ventilation program in the following cases:
 - regularly if there is high atmospheric humidity in the interior
 - if you need to switch off the ventilation unit.

This will remove any condensate that is present in the ventilation unit.
- ▶ Maintain the temperature in bedrooms at 16 °C to 18 °C or more. This temperature is also more healthy for the people in the bedrooms. Do not run the ventilation unit at room temperatures below 15 °C, and particularly not at low external temperatures below -5 °C. Otherwise the ventilation unit will constantly activate the frost protection function or switch off altogether. The higher the interior temperature, the bigger the buffer for operating the ventilation unit and for heat recovery.

NOTICE

Supply air or exhaust air operation alone is not recommended. Firstly because the unit is often in the unbalanced frost protection mode and secondly because the incoming flow of cold outdoor air causes the rooms to cool down.

6.3 Summer mode

On hot summer days, the heat recovery effect can be utilized the opposite way around during the day by correcting the temperature of the supplied hot outdoor air with the removed cooler extract air.

At night, when the outdoor air temperature is lower than the interior temperature, the ventilation unit can be set to allow supply air or extract air operation, with the effect that there is only limited heat recovery. In addition, a cross-ventilation effect can be created by setting one ventilation unit to supply air operation and the other to extract air operation.

In supply air mode, the exhaust air fan switches to the lowest ventilation level, i.e. considerably more supply air is transported. The necessary extract air flow rate must be guaranteed by arrangements in the building (e.g. tilted window) or a second unit.

The supply air or extract air mode program can be implemented using the optional controller options (app, wireless remote control, 4-way wireless pushbutton switch, the wireless humidity/CO₂ sensors) or using special factory settings.

NOTICE

- ▶ In the summer months, ventilate cellars and similar rooms only during the night or using a dew point ventilation controller (provided by the customer). Otherwise condensation from the atmospheric humidity can cause damage due to damp on the cold walls.

6.4 Air filters

- Never run the ventilation unit without air filters.
- Always use genuine Meltem filters. These are precisely matched to your M-WRG ventilation units, ensure minimal pressure losses and will ensure a long service life from your ventilation units.
- DIN 1946-6 “Ventilation for residential buildings” recommends changing air filters every six months. The air filters for outdoor air and extract air should be replaced at least once a year on hygiene grounds, ideally before the cold weather starts.
- In high levels of air pollution (e.g. from road traffic or industry, rooms with high dust levels) change the air filters **every six months**.
- Always replace air filters in pairs. The permeability of both air filters affects the efficiency and power consumption of the ventilation unit.
- Observe the filter change indicator (see chapter 12 on page 25) and replace the air filters as necessary.

NOTICE

An outdoor air filter from filter class ISO ePM1 ≥50% (F7) is needed to fulfil the hygiene requirements defined in VDI 6022 and DIN 1946-6 (category H). This is available as an option.

7 Controls on the ventilation unit

Item	Designation
1	Mains switch O = Ventilation unit “Off” I = Ventilation unit “On”
2	Step switch for 4 power levels: Ventilation level I = 15 m ³ /h Ventilation level II = 30 m ³ /h Ventilation level III = 60 m ³ /h Intensive ventilation level: Switching sequence I-II-I = 97 m ³ /h (15 min)

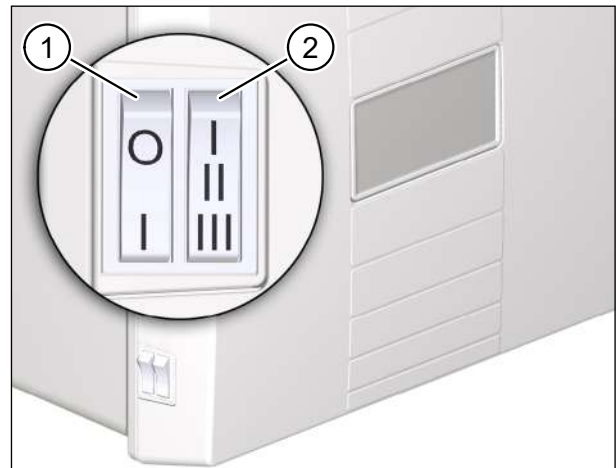

Fig. 10: Controls on the ventilation unit

NOTICE

The optional control variants app and wireless remote control are used to control, program and extend the range of functions of the M-WRG-S units. The functionality of the ventilation levels on the step switch can thus be adapted to suit the customer’s requirements. You will find more details in the associated user guide (see section 1.11 on page 10).

8 Starting up

8.1 Checking the ventilation unit before switching on for the first time

- ▶ Check the ventilation unit for damage.
- ▶ Check that the openings for extract air and supply air (see Fig. 11 and Fig. 12) are unobstructed.

8.2 Switching on the ventilation unit

- ▶ Switch the ventilation unit on at the mains switch (item 1 in Fig. 10 on page 20). After approx. 10 s, the air flaps on the extract air and supply air openings open.

8.3 Check position of air flaps

- ▶ Check the position of the air flaps (see Fig. 11 and Fig. 12) on the extract air and supply air openings.
 - Both air flaps will be closed if the ventilation unit is switched off or without power (see item 1 in Fig. 11).
 - Both air flaps open when you switch on (see item 1 in Fig. 12).

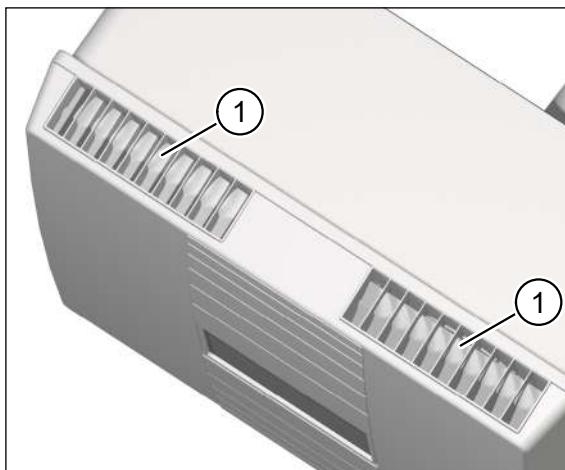

Fig. 11: Air flaps closed

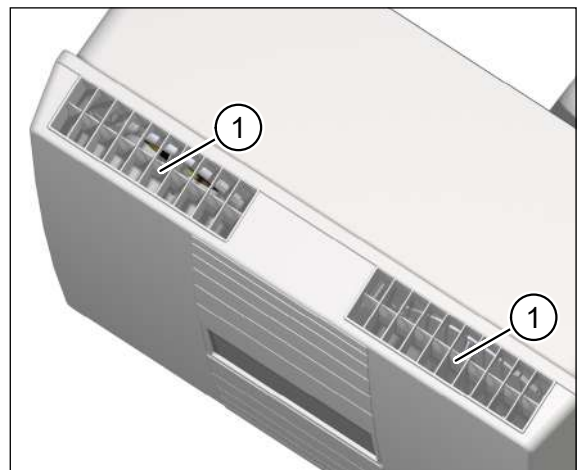

Fig. 12: Air flaps open

NOTICE

If the air flaps do not open fully after switching on for the first time or after a longer stoppage, follow the steps below:

- ▶ Switch the ventilation unit off.
- ▶ Wait at least 15 s.
- ▶ Switch the ventilation unit on again.

The air flaps should open fully. If this is not the case, repeat the above steps.

9 Operating the ventilation unit

9.1 Setting the ventilation level/program on the step switch

The step switch (item 2 in Fig. 10 on page 20) is used to set four different ventilation levels/programs (see section 10 on page 23); the maximum ventilation level is activated using a switching sequence and is time-limited.

Switch position	Ventilation level/program	Air flow
I	Reduced ventilation (people absent)	15 m ³ /h
II	Normal ventilation (people present)	30 m ³ /h
III	Increased ventilation	60 m ³ /h
Switching sequence I-II-I	Intensive ventilation (15 min)	97 m ³ /h

NOTICE

- Selecting switching sequence I-II-I on the step switch within two seconds results in 15 minutes of intensive ventilation at maximum ventilation level (97 m³/h). The ventilation unit then resumes operation at the previously set ventilation level.
- You can cancel intensive ventilation while it is running by selecting switching sequence I-II-I again.

9.2 Frost protection function

The ventilation unit is equipped with a frost protection function. In low outdoor temperatures, the ventilation unit automatically switches to frost protection mode.

- Do not switch the ventilation unit off in the winter. Note section “6 Rules for correct usage” on page 18.

How it works:

To prevent the heat exchanger from icing up, there is a temperature sensor fitted on the exhaust air side for constantly monitoring the temperature. If the exhaust air temperature drops below 2 °C, the motor controller gradually changes the supply air and/or extract air volume flow according to the fan level so that the proportion of extract air is increased. This causes the temperature to rise on the exhaust air side. When an exhaust air temperature of 4 °C is maintained for a period of 3 minutes, the unit switches back to the previous operating state. If a temperature of 2 °C is not achieved on the exhaust air side, despite increasing the proportion of extract air, e.g. because the room has cooled down, the extract air and supply air fans are switched off. As soon as a value of 4 °C is identified at the exhaust air temperature sensor, Ventilation mode is resumed at the fan level that was set before it was switched off.

10 Ventilation levels/programs

The M-WRG-S ventilation unit has the following ventilation levels/programs as standard:

10.1 “Reduced ventilation (people absent)”

The ventilation unit runs at the lowest ventilation level (15 m³/h). This operating mode can be selected when the occupier is absent (e.g. on holiday) to ensure a minimum level of air renewal. This includes ventilation for moisture protection.

10.2 “Normal ventilation (people present)”

The ventilation unit runs at the middle ventilation level (30 m³/h). This is the normal mode used to achieve the ventilation needed to meet hygiene and health requirements when the users are present.

10.3 “Increased ventilation”

The ventilation unit runs at a higher ventilation level (60 m³/h) in order to dissipate load peaks, e.g. when there are multiple people present or increased odour nuisance.

10.4 “Intensive ventilation (temporary 15 min)”

The ventilation unit runs at maximum ventilation level (97 m³/h). After roughly 15 minutes or when the I-II-I switching sequence is repeated on the step switch (item 2 in Fig. 10 on page 20), the intensive ventilation is ended and the previously set ventilation program is resumed.

11 Options for ventilation mode

11.1 External control input

11.1.1 Description

With the external control input supplied as standard, the M-WRG unit has an additional input terminal for 230 V AC (working voltage range: 85 V AC to 265 V AC / 50 - 60 Hz) to which a switch, time switch, motion detector or similar may be connected.

The external control input is equipped with a time-delay relay that can be used to set a switch-on delay and a run-on time:

- Switch-on delay:
the M-WRG unit does not start until the set time has elapsed.
- Run-on time:
the M-WRG unit does not switch to the previously active ventilation program until the set time has elapsed.

Windowless rooms can be ventilated in accordance with DIN 18017-3 in combination with the M-WRG-O/NOF option, part no. 5046-10.

11.1.2 Factory defaults and possible adjustment ranges

Parameter	Factory defaults	Possible adjustment ranges
Air flow	60 m ³ /h	15 to 97 m ³ /h
Switch-on delay	1 min	0 to 240 min
Run-on time	15 min	0 to 240 min

NOTICE

The above parameters can be changed either at the factory or using the optional wireless remote control M-WRG-FBH.

11.1.3 M-WRG-O/EST-1, part no. 5046-31, and M-WRG-O/EST-2, part no. 5046-32

The following options may be selected in addition to the external control input which is supplied as standard:

- M-WRG-O/EST-1: without switch-on delay, needs to be fitted at the factory
- M-WRG-O/EST-2: without run-on time, needs to be fitted at the factory

11.2 Parameter settings for special air outputs for all M-WRG units, M-WRG-O/PARM, part no. 5046-00

This option is used to set special air output parameters for all M-WRG units. It needs to be fitted at the factory.

11.3 Minimum ventilation to DIN 18017-3, M-WRG-O/MVS, part no. 5046-11

This option guarantees a minimum ventilation level to DIN 18017-3. Between 08:00 and 20:00, the unit ventilates at 40 m³/h, dropping to 20 m³/h between 20:00 and 08:00. The function is activated at the factory, cannot be switched off by the user and has priority over all other settings. It includes the mains switch without function so that the user cannot easily switch the unit off (it can be switched off via the building's fuse box, for example). This option changes the level assignment on the control units for the ventilation unit: switch position I, II, III: 20, 40, 60 m³/h.

11.4 Mains switch without function, M-WRG-O/NOF, part no. 5046-10

The mains switch on the ventilation unit is deactivated with this option. The user can only change the unit's ventilation levels / programs. However it must be ensured that the ventilation unit(s) can be switched off by other means (e.g. via the fuse box in the apartment or house). This option must be fitted at the factory.

11.5 Allergy filter replacement, M-WRG-O/Filter-FA, part no. 5046-50

The standard filter M-WRG-FS has been replaced with the allergy filter M-WRG-FA (for outdoor air only). The fine filter medium effectively retains pollen and respirable fine dust particles such as soot and bacteria from dust class PM1.

12 Filter maintenance

The ventilation unit has a runtime-controlled filter monitoring function with audible indicator. It monitors the time since the last air filter change. If the last air filter change was more than one year ago, the filter change indicator is activated and a pending air filter change is signalled.

As the time for the air filter change approaches, the intervals between the audible warnings shorten over a period of two to three weeks. The air filters must be changed when the warning signal occurs every hour and lasts for one second. This long warning period allows the user to order replacement filters in good time.

No tools are needed to change the air filters.

NOTICE

► Follow the instructions for changing the air filters in section 6.4 on page 20.

12.1 Choice of filter

The following air filters may be used or are available for selection for the M-WRG-S ventilation unit:

Part no.	Designation	Filter type	Filter class	Application
5571	M-WRG-FS	Standard filter (for outdoor air and extract air)	ISO ePM10 65% (G4)	Effectively retains coarse dust particles from dust class PM10 such as dust, pollen and fungal spores.
5572	M-WRG-FA	Allergy filter (for outdoor air only)	ISO ePM1 60% (F7)	Effectively filters out respirable particulates such as pollen, soot and bacteria from dust class PM1
5573	M-WRG-FK	Activated charcoal filter (for outdoor air only)	ISO ePM10 60% (M6)	Effectively retains coarse dust particles from dust class PM10 such as pollen and fungal spores, and the activated charcoal layer absorbs odours and harmful gases such as propellants, nitrogen oxides and ozone.

Table 3: Choice of filter

12.2 Ordering filters

Please contact your local or regional dealer for information on ordering filters. You will find the contact details on our website at www.meltem.com (or using the QR code on this page).

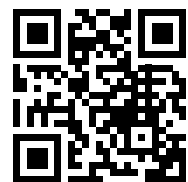

Go to
www.meltem.com

12.3 Changing the air filters

NOTICE

- ▶ Always switch the ventilation unit off at the mains switch (item 1 in Fig. 10 on page 20) for the filter change. On ventilation units with the M-WRG-O/NOF option, power to the unit must be switched off using the building's miniature circuit breaker. Otherwise the open air flaps (see Fig. 12 on page 21) will make it impossible to remove and insert the filter cartridges.

12.3.1 Removing the unit cover from the ventilation unit

- ▶ Using both thumbs, press the two latches (item 1 in Fig. 13) on the bottom of the ventilation unit. The unit cover will come away.
- ▶ At the same time, push your index fingers into the gap between the unit cover and housing, and lift the unit cover up and away from the housing.

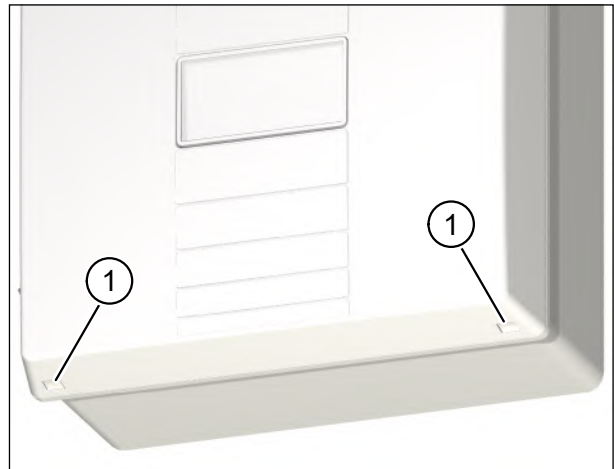

Fig. 13: Removing the unit cover from the ventilation unit

12.3.2 Remove air filters

- ▶ Turn the filter ring (item 1 in Fig. 14) using the hand grip (item 2 in Fig. 14) anti-clockwise until the arrow on the filter ring (item 3 in Fig. 14) lines up with the arrow at the removal position (item 4 in Fig. 14).
- ▶ Pull the filter ring together with the extract air filter out of the ventilation unit.
- ▶ Turn the filter cover (item 6 in Fig. 14) using the hand grip (item 7 in Fig. 14) anti-clockwise until the arrow (item 8 in Fig. 14) on the filter cover lines up with the arrow at the removal position (item 9 in Fig. 14).

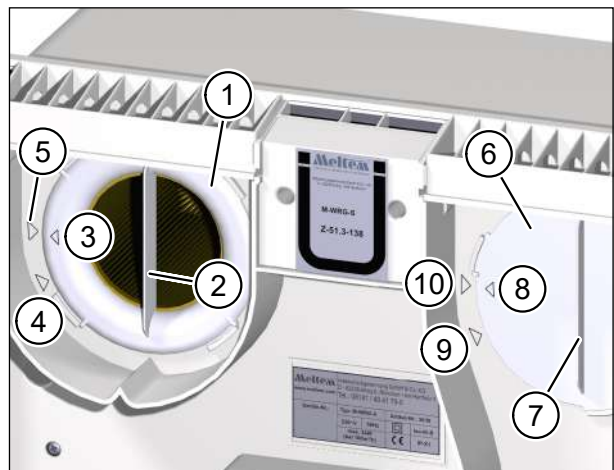

Fig. 14: Remove air filters

- ▶ Pull the filter cover together with the outdoor air filter out of the ventilation unit.
- ▶ Detach the extract air filter from the filter ring.
- ▶ Detach the outdoor air filter from the filter cover.

- ▶ Clean the filter ring and filter cover with a damp cloth if they are dirty (see chapter 13).
- ▶ Dispose of the used air filters in the non-recyclable waste or as required by your country's disposal regulations.

12.3.3 Insert new air filters

- ▶ Carefully guide the extract air filter into the ventilation unit.
- ▶ Make sure that the air filter slides into the four retaining tabs (item 1 in Fig. 15) on the back wall of the ventilation unit.
- ▶ Place the filter ring on the extract air filter. Make sure that the filter ring lies flat on the intermediate plate (item 2 in Fig. 15).
- ▶ Make sure that the filter ring is oriented so that the arrow on the filter ring (item 3 in Fig. 14 on page 26) lines up with the arrow for the removal position (item 4 in Fig. 14 on page 26).
- ▶ Turn the filter ring clockwise until the arrow on the filter ring (item 3 in Fig. 14 on page 26) lines up with the arrow for the locking position (item 5 in Fig. 14 on page 26).
- ▶ Insert the new outdoor air filter. Repeat the steps described for the extract air filter.
- ▶ Check the position of the filter ring and filter cover. The hand grips must be vertical and the arrows on the filter ring and filter cover must line up with the arrows for the locking position (see Fig. 14 on page 26).

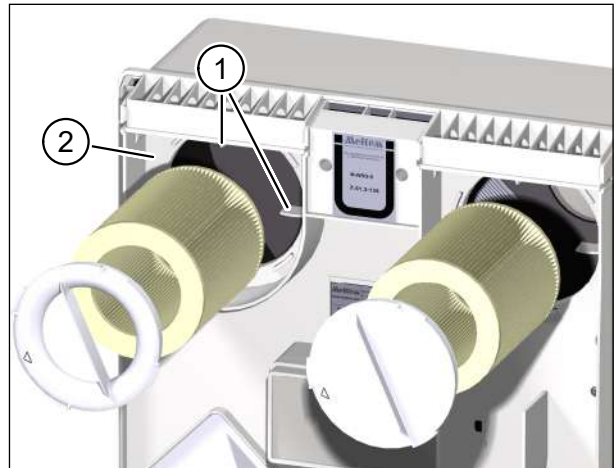

Fig. 15: Insert air filters

NOTICE

- The ventilation unit will not work as well if the filter ring or filter cover is not inserted correctly.
- Allergy filters and activated charcoal filters may only be used as outdoor air filters.

12.3.4 Attaching the unit cover to the ventilation unit and switching on the ventilation unit

- ▶ Hold the cover (item 1 in Fig. 16) of the ventilation unit with both hands and tilt the top edge of the cover towards the ventilation unit.
- ▶ Insert the tabs (item 2 in Fig. 16) of the unit cover into the openings (item 3 in Fig. 16) on the top of the ventilation unit.
- ▶ Lightly press the bottom edge of the cover against the ventilation unit until you hear the cover snap in place.
- ▶ Switch the ventilation unit on at the mains switch (item 1 in Fig. 10 on page 20).

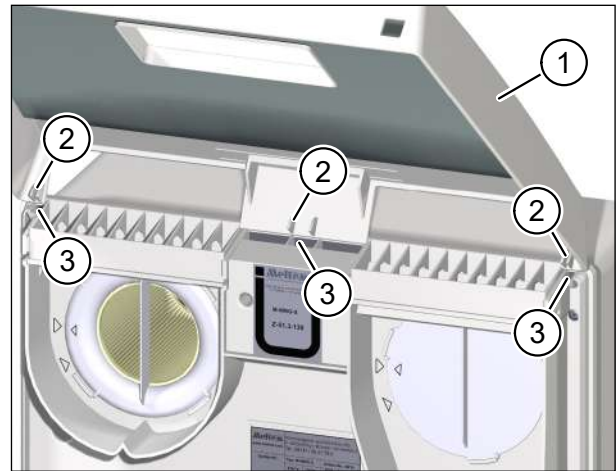

Fig. 16: Attaching the unit cover to the ventilation unit

12.3.5 Resetting the filter change indicator

NOTICE

The filter change indicator must be reset on ventilation units built from 06/2017.

After every air filter change, the filter change indicator must be reset in order to restart monitoring of the period since the last air filter change. The procedure is as follows:

- ▶ Within three seconds, select the ventilation levels **I-II-III-II-I** one after the other on the step switch (item 1 in Fig. 17).
The ventilation unit will beep as confirmation.
- ▶ Within three seconds, while the ventilation unit is beeping, again select the ventilation levels **I-II-III-II-I** one after the other on the step switch (item 1 in Fig. 17).

The ventilation unit will beep three times as confirmation. Monitoring of the period since the last air filter change is now restarted.

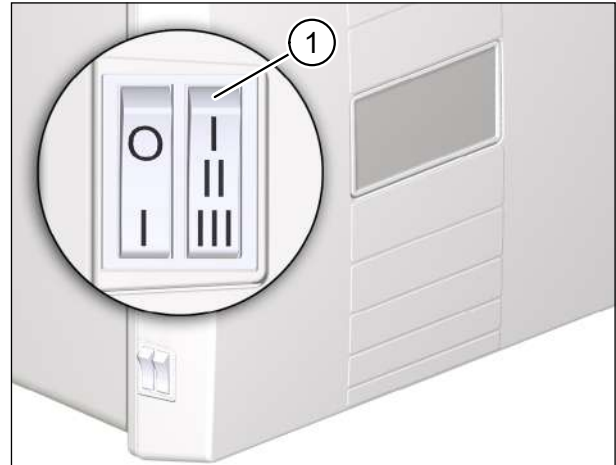

Fig. 17: Resetting the filter change indicator

13 Cleaning and maintenance

WARNING

- ▶ Switch off the power to the ventilation unit before cleaning.
- ▶ When cleaning, make sure that no moisture penetrates into the inside of the housing.
- ▶ Never use a high pressure cleaner, steam cleaner or steam jet.

The ventilation unit is made of high quality plastic and requires little care.

- ▶ Wipe the outer surfaces from time to time with a soft, damp cloth. Use mild soapy water. A commercially available plastic cleaner can be used for particularly stubborn dirt.

NOTICE

- ▶ Never use acidic, corrosive or abrasive cleaning agents.

Maintenance of the M-WRG series of units is described in separate maintenance instructions (see section “1.11 Supplementary documents” on page 10).

14 Troubleshooting

Error	Cause	Remedy
Ventilation unit is not running	Ventilation unit is in safe mode after an EMC fault	Switch the ventilation unit off, wait 15 seconds, then switch on
	Installation error	Have the wiring checked by a qualified electrician
	Faulty switch, motor or controller	Check by a qualified electrician
Air flaps do not open after switching on	After a long stoppage or when starting up for the first time, the servomotor is not powered by the electronic circuit.	Switch the ventilation unit off and on again
	Air flap range of motion is blocked by foreign bodies (plaster, polystyrene, etc.)	Carefully remove the foreign bodies, remove the unit cover if necessary (see “12.3.1 Removing the unit cover from the ventilation unit” on page 26)
Ventilation unit starts to beep at intervals	— Filter change interval exceeded	Change air filters (see “12.3 Changing the air filters” on page 26)
The ventilation unit frequently activates the frost protection function	— The air filter is very dirty (in areas with highly polluted outdoor air this can occur even before the filter change interval has elapsed)	
Operating noise of the ventilation unit increases in volume		

Table 4: Troubleshooting

Space for your notes



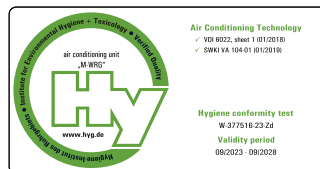

We have checked the content of this publication for conformity with the product described in it. There may nevertheless still be differences, so we cannot guarantee complete accuracy.

The information in this publication is regularly checked and any necessary corrections are made in subsequent editions.

Copyright © Meltem Wärmerückgewinnung GmbH & Co. KG

We reserve the right to make changes.

Meltem Wärmerückgewinnung GmbH & Co. KG
Am Hartholz 4
D-82239 Alling
Germany
Tel. +49 8141 404179-0
Fax +49 8141 404179-9
Internet: www.meltem.com
Email: info@meltem.com



Go to
Meltem download area

