

SINGLE-ROOM VENTILATION UNITS FOR BATHROOMS, TOILETS AND KITCHENS

VARIO II



AIR EXTRACTION FOR BATHROOMS, TOILETS AND KITCHENS

A BREATH OF FRESH AIR

in ventilation technology



VISIONS FOR THE FUTURE

Innovation means progress. Only visionaries can master the new challenges facing their products. Our focus is on saving energy and customer benefit.

As specialists in single room ventilation units and decentralised system solutions, we consistently incorporate the latest electronics and high quality components into our products to meet the most rigorous technical requirements. Our innovative capacity, which underscores the uniqueness

of our technology, is proven through numerous patents. High-end components and precision engineering guarantee a long service life and excellent reliability. **For more than 40 years, the Meltem name has stood for the highest quality** in ventilation technology.

This expertise enables us to supply proven, finely-tuned ventilation systems so you can create a healthy climate and make life within your home more comfortable.



VARIO II ClassicLine



We take "Made in Germany" literally: as a binding quality standard.

Health and well-being are dependent on good air. The Meltem VARIO II series supplies clean air in bathrooms, toilets and kitchens, eliminates unpleasant odours and protects against moisture damage. VARIO II units are powerful, easy to install and – apart from filter changes – maintenance-free. You can create the perfect unit by combining the surface-mount or flush-mount box and fan insert that meet your needs. Meltem has the perfect solution for every ventilation application and is the smart choice for environmentally-conscious homeowners looking to minimise energy usage. And indeed for anyone who simply loves fresh air.

QUALITY MADE IN GERMANY

Premium materials and precision engineering guarantee a long service life. The Meltem name is your guarantee of quality; decades of experience with single room ventilation units are incorporated into the VARIO II series. Of course, all units are **TÜV-tested and have building inspectorate approval.**

Benefits:

- **Protection against moisture damage and prevention of mould growth**
- **Several different control options**
- **High air flow rate due to steep pressure-volume flow rate characteristic**

VARIO II fan inserts

- Several different control options
- Energy-saving, low-noise and maintenance-free precision external rotor motor with overload protection
- Steep pressure-volume flow rate characteristic (see technical data) due to high-performance radial wheel with embedded steel disc
- Protection class II (protective earth conductor “PE” is not needed)
- 230 V – 50 Hz, RI-suppressed
- IP rating IP–X5 (suitable for installation in zone 1 to DIN VDE 0100 Part 701 in showers)

Functions / Adjustment ranges

Fan	Switch-on delay	Run-on time	Interval time	Humidity control	Circuit diagram
V-II 30					1
V-II 60					1
V-II 100					1
V-II 30-N	approx. 3 s to 2.5 min	approx. 3 to 20 min			2
V-II 60-N	approx. 3 s to 2.5 min	approx. 3 to 20 min			2
V-II 100-N	approx. 3 s to 2.5 min	approx. 3 to 20 min			2
V-II 30-I		approx. 3 to 20 min	approx. 1 to 12 h		2
V-II 60-I		approx. 3 to 20 min	approx. 1 to 12 h		2
V-II 100-I		approx. 3 to 20 min	approx. 1 to 12 h		2
V-II 30-BM-N		approx. 3 to 20 min			8
V-II 60-BM-N		approx. 3 to 20 min			8
V-II 100-BM-N		approx. 3 to 20 min			8
V-II 30-BM-I		approx. 3 to 20 min	approx. 1 to 12 h		8
V-II 60-BM-I		approx. 3 to 20 min	approx. 1 to 12 h		8
V-II 100-BM-I		approx. 3 to 20 min	approx. 1 to 12 h		8
V-II 60-F		approx. 15 min		20 to 95 % RH* 75 % RH**	2
V-II 100-F		approx. 15 min		20 to 95 % RH* 75 % RH**	2
V-II 30/60					3 or 7
V-II 30/100					3 or 7
V-II 30/60-NZ	approx. 3 s to 2.5 min	approx. 3 to 20 min			2
V-II 30/100-NZ	approx. 3 s to 2.5 min	approx. 3 to 20 min			2
V-II 30/60-K	approx. 3 s to 2.5 min	approx. 3 to 20 min			2
V-II 30/100-K	approx. 3 s to 2.5 min	approx. 3 to 20 min			2
V-II 30/60-KF	approx. 3 s to 2.5 min	approx. 3 to 20 min			5
V-II 30/100-KF	approx. 3 s to 2.5 min	approx. 3 to 20 min			5
V-II 30/60-KF-LX	approx. 3 s to 2.5 min	approx. 3 to 20 min			6
V-II 30/100-KF-LX	approx. 3 s to 2.5 min	approx. 3 to 20 min			6
V-II 30/60-KZ	approx. 3 s to 2.5 min	approx. 3 to 20 min			4
V-II 30/100-KZ	approx. 3 s to 2.5 min	approx. 3 to 20 min			4
V-II 30/60-F		approx. 15 min		20 to 95 % RH* 75 % RH**	2
V-II 30/100-F		approx. 15 min		20 to 95 % RH* 75 % RH**	2
V-II 30/60/100					9

For factory default setting, see “Functions” (page 5 - 13)

* Humidity control range ** Fixed switching point (see instructions for description of the functions)

You can combine the fan inserts with all the boxes from the VARIO II series.

All VARIO II ventilation units have national technical approval (DIBt Z-51.1-309) and IP rating IP-X5.

Single-stage fan inserts with filter holder, air filter and cover

without control

Designation:

Part no.: 2200	V-II 30
Part no.: 2210	V-II 60
Part no.: 2220	V-II 100

The fan starts as soon as the unit is switched on.
The fan stops as soon as the unit is switched off.

with run-on control ⁽¹⁾

Designation:

Part no.: 2205	V-II 30-N
Part no.: 2215	V-II 60-N
Part no.: 2225	V-II 100-N

Integrated run-on control for infinitely-variable adjustment of the switch-on delay and run-on time.
Potentiometer for easy setting.

When the unit is switched on, the fan starts after a switch-on delay of 1 min*.

When the unit is switched off, the fan stops working after a 15 min* run-on time.

* Factory setting

Possible settings:

- *Infinitely-variable switch-on delay from 3 s to 2.5 min*
- *Infinitely-variable run-on time from 3 to 20 min*

⁽¹⁾ Ventilation to DIN 18017-3, also V-II 30-N for use in toilet rooms

Single-stage fan inserts with filter holder, air filter and cover

with interval and run-on control ⁽¹⁾

Designation:

Part no.: 2206	V-II 30-I
Part no.: 2216	V-II 60-I
Part no.: 2226	V-II 100-I

Integrated interval and run-on control. Potentiometer for easy setting.

The fan starts as soon as the unit is switched on.

When the unit is switched off, the fan stops working after a 15 min* run-on time. Interval mode starts after the last time the fan was switched off. The fan is out of use for the default interval time of approx. 1 h*. The fan then runs on for 15 min*.

* Factory setting

Possible settings:

- *Infinitely-variable run-on time from 3 to 20 min*
- *Infinitely-variable interval mode from 1 h to 12 h*

with motion detector and run-on control ⁽¹⁾

Designation:

Part no.: 2203	V-II 30-BM-N
Part no.: 2213	V-II 60-BM-N
Part no.: 2223	V-II 100-BM-N

Integrated run-on control for infinitely-variable adjustment of the run-on time.

Potentiometer for easy setting.

The motion detector registers people within the detection range and triggers a switching signal. The fan starts immediately. When the person leaves the detection range, the fan stops working after a 15 min* run-on time. If the motion detector registers a person before the run-on time has elapsed, the run-on time restarts when the person leaves the detection range.

* Factory setting

- **Motion detector**

Possible settings:

- *Infinitely-variable run-on time from 3 to 20 min*

⁽¹⁾ Ventilation to DIN 18017-3

Single-stage fan inserts with filter holder, air filter and cover

with motion detector, interval and run-on control ⁽¹⁾

Designation:

Part no.: 2204	V-II 30-BM-I
Part no.: 2214	V-II 60-BM-I
Part no.: 2224	V-II 100-BM-I

Integrated run-on control for infinitely-variable adjustment of the run-on time. Potentiometer for easy setting.

The motion detector registers people within the detection range and triggers a switching signal. The fan starts immediately. When the person leaves the detection range, the fan stops working after a 15 min* run-on time. If the motion detector registers a person before the run-on time has elapsed, the run-on time restarts when the person leaves the detection range. Interval mode starts after the last time the fan was switched off. The fan is out of use for the default interval time of approx. 1 h*. The fan then runs on for 15 min*.

* Factory setting

- **Motion detector**

Possible settings:

- *Infinitely-variable run-on time from 3 to 20 min*
- *Infinitely-variable interval mode from 1 h to 12 h*

with humidity control

Designation:

Part no.: 2217	V-II 60-F
Part no.: 2227	V-II 100-F

The humidity control has a fixed switching point of 75 % RH (relative humidity) or responds to a rapid rise in humidity. When the unit is switched on, the fan starts after the measured values have been recorded for approx. 50 s (60 or 100 m³/h). When the unit is switched off, the fan runs on for 15 min. The fan switches off if no increased humidity value is measured during this period. The humidity sensor has a measured control range from 20 % to 95 % RH and constantly monitors the room air humidity. The humidity sensor starts the fan in the following situations:

- Rapid rise in humidity regardless of the current room air humidity
- The switching point of 75 % RH is exceeded.

The integrated tropics function adapts the humidity sensor to the atmosphere in the room which changes according to the time of year. The tropics function also incorporates a running time limiter which switches the fan off after 12 h uninterrupted service. Example of a rapid rise in humidity: The room humidity is 45 % RH. While the shower is in use, the fan starts due to the rapid rise in humidity, even if the 75 % RH switching point has not yet been reached.

- **Fan running at 60 or 100 m³/h**
- **Run-on time 15 min**
- **Measured control range from 20 % to 95 % RH**
- **Fixed switching point of 75 % RH**
- **Responds to a rapid rise in humidity regardless of the current room air humidity (RH)**
- **Running time limiter**

⁽¹⁾ Ventilation to DIN 18017-3

Two-stage fan inserts with filter holder, air filter and cover

without control ⁽¹⁾

Designation:

Part no.: 2230	V-II 30/60
Part no.: 2240	V-II 30/100

The fan runs continuously either in base load operation (30 m³/h) or in nominal load operation (60 or 100 m³/h). A switch is used to toggle between base load operation and nominal load operation.

- **Continuous base load operation 30 m³/h**
- **While the room is in use, nominal load operation at 60 or 100 m³/h**

with run-on control ⁽¹⁾

Designation:

Part no.: 2231	V-II 30/60-NZ
Part no.: 2241	V-II 30/100-NZ

Integrated run-on control for infinitely-variable adjustment of the switch-on delay and run-on time. Potentiometer for easy setting.

The fan runs continuously in base load operation (30 m³/h).

When the unit is switched on, the fan runs in nominal load operation after a switch-on delay of approx. 1 min* (60 or 100 m³/h). When the unit is switched off, the fan runs on for 15 min* in nominal load operation. The fan then switches to base load operation.

* Factory setting

- **Continuous base load operation 30 m³/h**
- **Nominal load operation 60 or 100 m³/h**
- **Run-on time in nominal load operation 60 or 100 m³/h**

Possible settings:

- *Infinitely-variable switch-on delay from 3 s to 2.5 min*
- *Infinitely-variable run-on time from 3 to 20 min*

⁽¹⁾ Ventilation to DIN 18017-3

Two-stage fan inserts with filter holder, air filter and cover

with comfort control

Designation:

Part no.: 2232	V-II 30/60-K
Part no.: 2242	V-II 30/100-K

Integrated run-on control for infinitely-variable adjustment of the switch-on delay and run-on time.
Potentiometer for easy setting.

When the unit is switched on, the fan runs in base load operation after a switch-on delay of approx. 1 min* (30 m³/h).
When the unit is switched off, the fan runs on for 15 min* in nominal load operation (60 or 100 m³/h).
The fan then switches off.

* Factory setting

- While the room is in use, base load operation 30 m³/h
- Run-on time in nominal load operation 60 or 100 m³/h

Possible settings:

- Infinitely-variable switch-on delay from 3 s to 2.5 min
- Infinitely-variable run-on time from 3 to 20 min

with comfort control and remote control input (potential-free 230 V AC)

Designation:

Part no.: 2233	V-II 30/60-KF
Part no.: 2243	V-II 30/100-KF

Integrated run-on control for infinitely-variable adjustment of the switch-on delay and run-on time.
Potentiometer for easy setting.

When the unit is switched on, the fan runs in base load operation after a switch-on delay of approx. 1 min* (30 m³/h).
When the unit is switched off, the fan runs on for 15 min* in nominal load operation (60 or 100 m³/h).
The fan then switches off.

This control is also equipped with a remote control input (230 V AC, internal, switchable via potential-free contact) to allow base load operation to be switched on and off using a switch provided by the customer.

* Factory setting

- While the room is in use, base load operation 30 m³/h
- Run-on time in nominal load operation 60 or 100 m³/h
- Base load operation switched on and off via a switch provided by the customer

Possible settings:

- Infinitely-variable switch-on delay from 3 s to 2.5 min
- Infinitely-variable run-on time from 3 to 20 min

Two-stage fan inserts with filter holder, air filter and cover

with comfort control and remote control input (230 V AC)

Designation:

Part no.: 2233-1	V-II 30/60-KF-LX
Part no.: 2243-1	V-II 30/100-KF-LX

Integrated run-on control for infinitely-variable adjustment of the switch-on delay and run-on time.
Potentiometer for easy setting.

When the unit is switched on, the fan runs in base load operation after a switch-on delay of approx. 1 min* (30 m³/h).
When the unit is switched off, the fan runs on for 15 min* in nominal load operation (60 or 100 m³/h).
The fan then switches off.

This control is also equipped with a remote control input (230 V AC, supplied externally) to allow base load operation to be switched on and off using a switch provided by the customer.

* Factory setting

- **While the room is in use, base load operation 30 m³/h**
- **Run-on time in nominal load operation 60 or 100 m³/h**
- **Base load operation switched on and off via a switch provided by the customer**

Possible settings:

- *Infinitely-variable switch-on delay from 3 s to 2.5 min*
- *Infinitely-variable run-on time from 3 to 20 min*

with comfort control and central control input (12/24 V)

Designation:

Part no.: 2234	V-II 30/60-KZ
Part no.: 2244	V-II 30/100-KZ

Integrated run-on control for infinitely-variable adjustment of the switch-on delay and run-on time.
Potentiometer on the fan for easy setting.

When the unit is switched on, the fan runs in base load operation after a switch-on delay of approx. 1 min* (30 m³/h).
When the unit is switched off, the fan runs on for 15 min* in nominal load operation (60 or 100 m³/h).
The fan then switches off.

This control is also equipped with a central control input for a 12/24 V AC control cable provided by the customer which is used to switch base load operation on and off from a central location.

* Factory setting

- **While the room is in use, base load operation 30 m³/h**
- **Run-on time in nominal load operation 60 or 100 m³/h**
- **Base load operation switched on and off via a switch provided by the customer**

Possible settings:

- *Infinitely-variable switch-on delay from 3 s to 2.5 min*
- *Infinitely-variable run-on time from 3 to 20 min*

Two-stage fan inserts with filter holder, filter and cover

with humidity control ⁽²⁾

Designation:

Part no.: 2235	V-II 30/60-F
Part no.: 2245	V-II 30/100-F

The humidity control has a fixed switching point of 75 % RH (relative humidity) or responds to a rapid rise in humidity. When the unit is switched on, the fan runs in base load operation (30 m³/h) after the measured values have been recorded for approx. 50 s. When the unit is switched off, the fan runs on for 15 min* in nominal load operation (60 or 100 m³/h). The fan switches off if no increased humidity value is measured during this period. The humidity sensor has a measured control range from 20 % to 95 % RH and constantly monitors the room air humidity. The humidity sensor switches the fan to base load operation in the following situations:

- Rapid rise in humidity regardless of the current room air humidity
- The switching point of 75 % RH is exceeded.

The integrated tropics function adapts the humidity sensor to the atmosphere in the room which changes according to the time of year. The tropics function also incorporates a running time limiter which switches the fan off after 12 h uninterrupted service in base load operation.

Example of a rapid rise in humidity:

The room humidity is 45 % RH. While the shower is in use, the fan switches to base load operation due to the rapid rise in humidity, even if the 75 % RH switching point has not yet been reached.

* Factory setting

- **While the room is in use, base load operation 30 m³/h**
- **Run-on time of 15 min in nominal load operation 60 or 100 m³/h**
- **Humidity mode in base load operation 30 m³/h**

⁽²⁾ Ventilation to DIN 18017-3 in combination with option part no. 2250-01 V-II O/F-DG

Two-stage fan inserts with filter holder, air filter and cover

Additional options for two-stage air filter inserts with humidity control (V-II 30/60-F, V-II 30/100-F)

Only one option can be selected per unit.

Designation:

Part no.: 2250-00	V-II O/F-ZU
-------------------	-------------

Central control input (timer) option:

An additional 24 V central control input allows the fan to also be operated in base load operation (30 m³/h). All other functions are identical to those of types V-II 30/60-F, V-II 30/100-F.

Designation:

Part no.: 2250-01, 2250-11	V-II O/F-DG
----------------------------	-------------

Continuous base load operation option:

In contrast to the standard fan, this type runs for 24 h in base load operation (30 m³/h). In humidity mode, the fan runs in nominal load operation (60 or 100 m³/h). The switch activates the time-delay relay. After the measured values have been recorded for approx. 50 s, the relay switches the fan to nominal load operation. When the fan is switched off, nominal load operation remains active for 15 min.

Designation:

Part no.: 2250-02	V-II O/F-BM
-------------------	-------------

Motion detector option:

In contrast to the standard fan, this fan is also equipped with a motion detector.

The motion detector switches the fan to base load operation (30 m³/h). When the unit is switched off, the fan runs on for 15 min in nominal load operation (60 or 100 m³/h). The fan switches off if no increased humidity value is measured during this period. All other humidity functions are identical to those of types V-II 30/60-F, V-II 30/100-F.

Designation:

Part no.: 2250-03	V-II O/F-FF
-------------------	-------------

Remote control input option:

This control is also equipped with a remote control input (230 V AC, internal, switchable via potential-free contact) to allow base load operation to be switched on and off using a switch provided by the customer. All other functions are identical to those of types V-II 30/60-F, V-II 30/100-F.

Three-stage fan inserts with filter holder, air filter and cover

Designation:

Part no.: 2248

V-II 30/60/100

The fan starts immediately when the desired air flow (30, 60 or 100 m³/h) is selected with the 3-way stepping switch. The fan stops immediately when the 3-way stepping switch is moved to the zero position.

Note for users

For the ventilation unit to remain functional, the air filter must be changed every 3 months and the regulating mat* should also be changed annually if it is dirty. Part no. 2670 VARIO II VF replacement filter includes a regulating mat.

Part number	Name of part	Contents	Size
2670	VARIO II VF replacement filter	Air filter, 5 x	16 x 20 cm
		Regulating mat, 1 x	13 x 20 cm

* Only for use with fan inserts with 60 m³/h and exhaust socket to the side (excluding part no. 2248 V-II CL-30/60/100).

Air filter replacement



Circuit diagrams

V-II 30, 60, 100

1

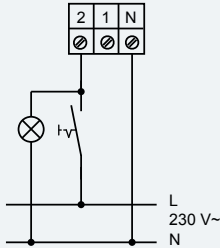

V-II 30-N (-I), 60-N (-I) (-F),
100-N (-I) (-F), 30/60-K (-F, -NZ),
30/100-K (-F, -NZ)

2

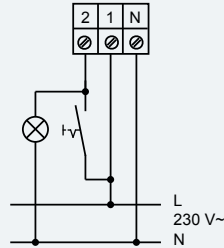

V-II 30/60, 30/100

3

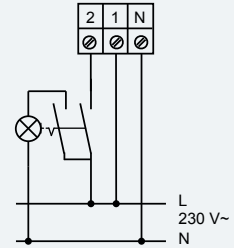

Note: Use a 2-pole switch.

V-II 30/60-KZ, 30/100-KZ

4

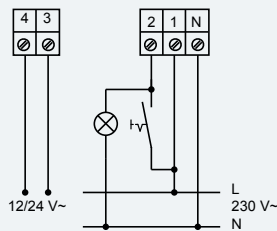

V-II 30/60-KF, 30/100-KF

5

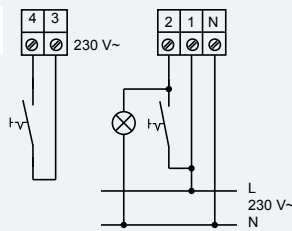

V-II 30/60-KF-LX, 30/100-KF-LX

6

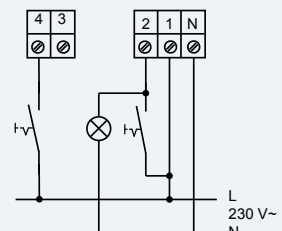

V-II 30/60, 30/100,
switchable base load operation

7

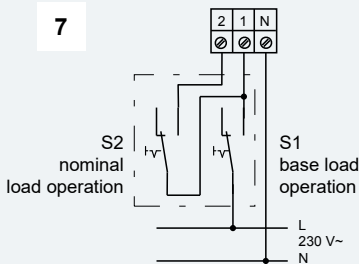

Note: Use a double toggle switch.

V-II 30-BM-N (-I), 60-BM-N (-I),
100-BM-N (-I)

8

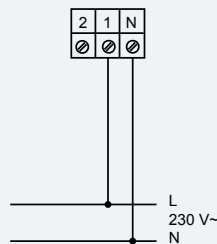

V-II 30/60/100

9

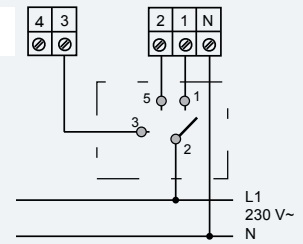

Attention: All wiring and modification work is to be carried out in accordance with VDE 0105 part 1 (by approved electricians). Incorrect wiring will result in damage to the controls and will invalidate all warranty claims. Subject to technical modifications.

CE mark: All controls fulfil the requirements of the following EC directives: EC Low Voltage Directive 73/23/EEC, EC Electromagnetic Compatibility Directive 89/336/EEC.



Flush-mount units

Technical data / VARIO II flush-mount installation									
	Installation position	Exhaust socket	Air flow in m ³ /h	Power in W	P _{el, fan} [W/(m ³ /h)]	Current consumption (at 0 Pa) in A	Pressure difference stat. (Pa)	Sound power level L _{WA} /dB(A)	Sound pressure level L _{pA} /dB(A)
Units with exhaust to the side									
U-V30	Wall	Top	29.4	6.2	0.21	0.08	49	30	26
UB-V30	Wall	Top	29.4	6.2	0.21	0.08	49	29	25
UBK-V30	Wall	Top	21.4	6.4	0.30	0.08	60	37	33
U-V60	Wall	Top	63.6	16.9	0.27	0.13	247	44.5	40.5
UB-V60	Wall	Top	63.6	16.9	0.27	0.13	247	43.5	39.5
UBK-V60	Wall	Top	62.8	17.5	0.27	0.13	177	45	41
U-V100	Wall	Top	100	27.7	0.28	0.16	168	51.5	47.5
UB-V100	Wall	Top	100	27.7	0.28	0.16	168	51.5	47.5
UBK-V100	Wall	Top	100	27.7	0.29	0.16	168	51.5	47.5
Units with exhaust to the rear									
U-H V30	Wall	Top left	29.6	6.1	0.21	0.07	48	31	27
UB-H V30	Wall	Top left	29.6	6.1	0.21	0.07	48	31	27
UBK-H-V30	Wall	Top left	21.8	6.2	0.28	0.07	63	38	34
U-H V60	Wall	Top left	65.4	17.3	0.27	0.12	184	45.5	41.5
UB-H-V60	Wall	Top left	65.4	17.3	0.27	0.12	181	44	40
UBK-H-V60	Wall	Top left	62.5	17.4	0.28	0.12	181	45	41
U-H V100	Wall	Top left	96.9	27.4	0.28	0.15	121	53.5	49.5
UB-H-V100	Wall	Top left	96.9	27.4	0.28	0.15	121	53.5	49.5
UBK-H-V100	Wall	Top left	96.9	27.4	0.29	0.15	121	54	50

Surface-mount units

Technical data / VARIO II surface-mount installation									
	Installation position	Exhaust socket	Air flow in m ³ /h	Power in W	P _{el, fan} [W/(m ³ /h)]	Current consumption (at 0 Pa) in A	Pressure difference stat. (Pa)	Sound power level L _{WA} /dB(A)	Sound pressure level L _{pA} /dB(A)
Units with exhaust to the side									
A-V30	Wall	Top left	29.6	6.1	0.21	0.07	48	33	29
AK-V30	Wall	Top left	21.8	6.2	0.28	0.07	63	41	37
A-V60	Wall	Top left	65.4	17.3	0.27	0.12	184	51.5	47.5
AK-V60	Wall	Top left	62.5	17.4	0.28	0.12	181	55.5	51.5
A-V100	Wall	Top left	96.9	27.4	0.28	0.15	121	55.5	51.5
AK-V100	Wall	Top left	96.9	27.4	0.29	0.15	121	58	54

Technical data

Flush-mount units

VARIO II flush-mount box installation dimensions

Type: U, UB, UBK

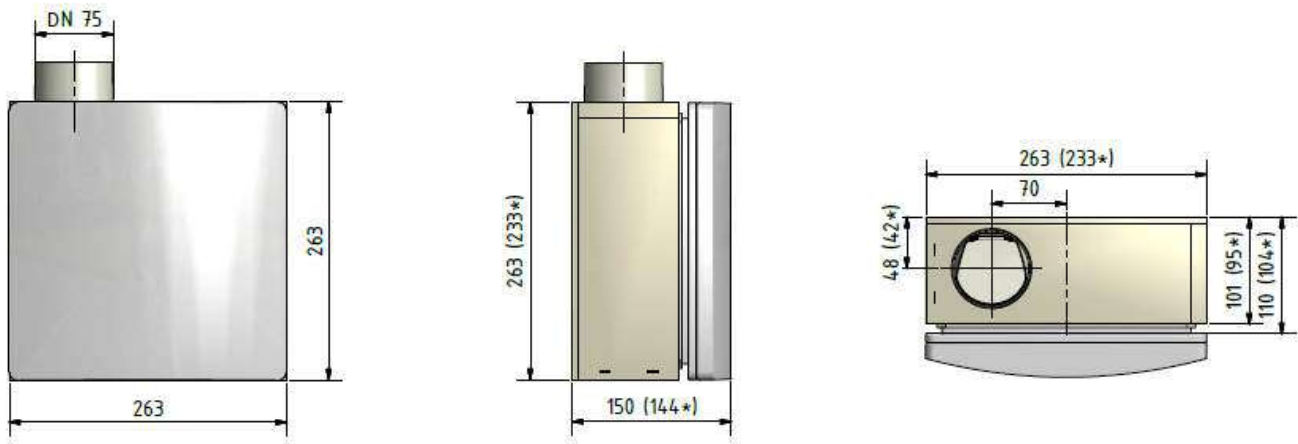

VARIO II flush-mount box installation dimensions

Type: U-H, UB-H, UBK-H,

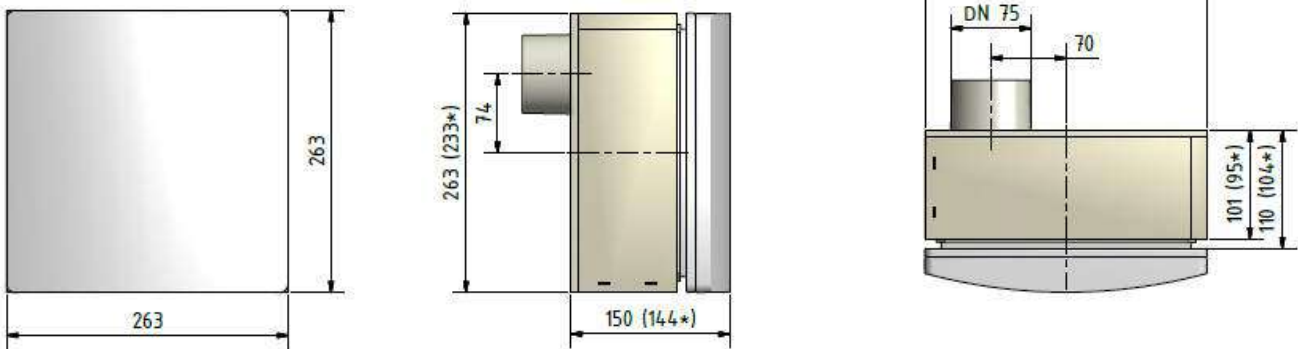

Surface-mount units

VARIO II surface-mount box installation dimensions

Type: A, AK

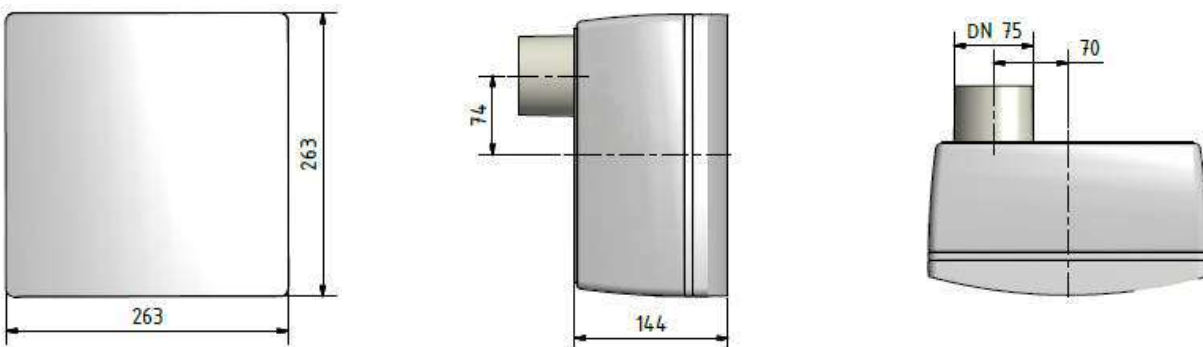

* Dimensions for box without fire protection casing

Installation positions

Installation position for flush-mount/surface-mount box with exhaust socket to rear /
 Type: A, AK, U-H, UB-H, UBK-H

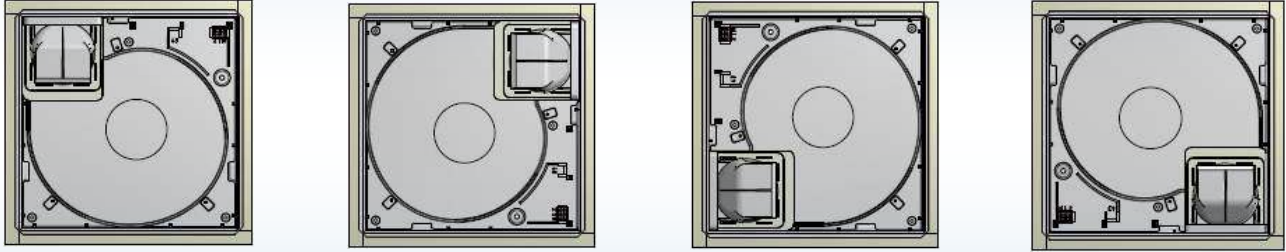

Installation position for flush-mount box with exhaust socket to the side
 Type: U, UB, UBK

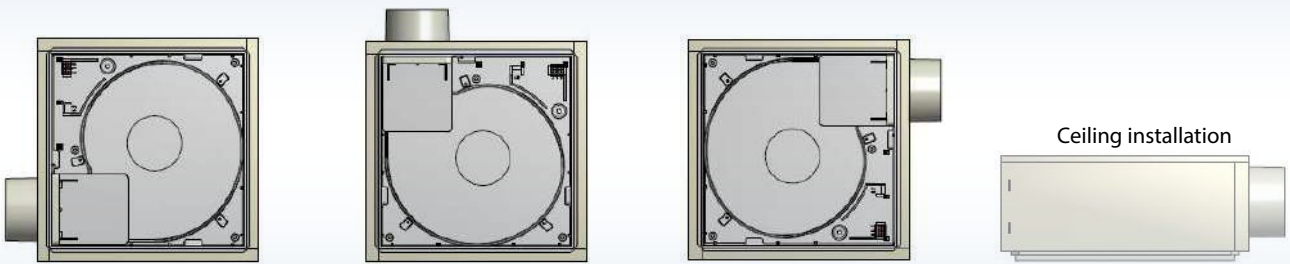

Dimensions of the main pipe

Pipe diameter for a simultaneity factor of 100 %.

The ducting schemes represent the minimum nominal pipe diameters and were determined in accordance with DIN 18017 part 3, August 2007-07 edition; the calculations were based on a height between floors of 2.75 m and a length of exhaust pipe from the last fan connection of up to 2 m. **Attention:** If different products are used, the riser ducts MUST be recalculated on the basis of the available pressure difference.

60 m³/h

Total number of floors	DN 100	DN 125	DN 140	DN 160	DN 180	DN 200
18						
17						
16						
15						
14						
13						
12						
11						
10						
9						
8						
7						
6						
5						
4						
3						
2						
1						

60 m³/h

Total number of floors	DN 100	DN 125	DN 140	DN 160	DN 180	DN 200
18						
17						
16						
15						
14						
13						
12						
11						
10						
9						
8						
7						
6						
5						
4						
3						
2						
1						

100 m³/h

Total number of floors	DN 100	DN 125	DN 140	DN 160	DN 180	DN 200
18						
17						
16						
15						
14						
13						
12						
11						
10						
9						
8						
7						
6						
5						
4						
3						
2						
1						

Fire protection

Installation in buildings with no fire resistance requirements
or in combination with a ceiling penetration seal

Single-room ventilation unit from the "VARIO II" series /
Example installations for unit Type: U and U-H

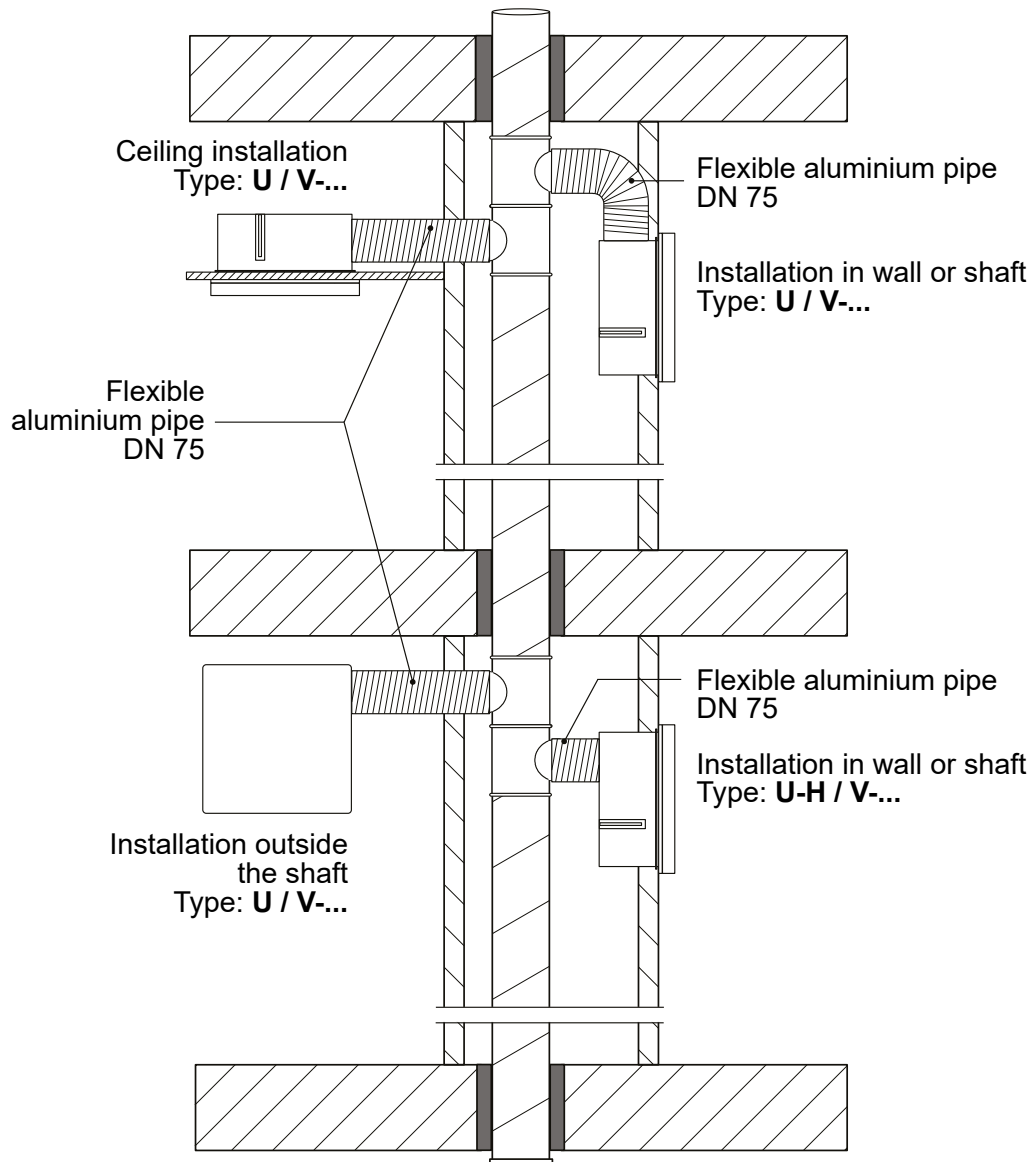

Installation instructions for buildings with fire resistance requirements

- Wall thickness at least 24 mm
The wall of the fire-resistant shaft or ventilation pipe must always be at least 24 mm thick and the mounting bracket MB-V part no. 4452 should be used.

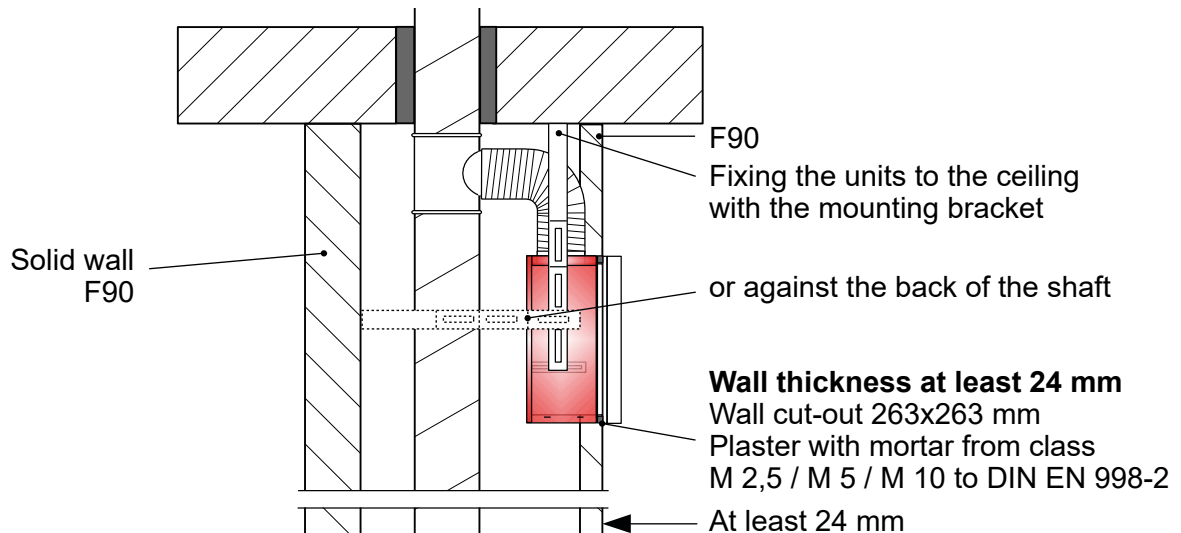

- If the wall thickness is 80 mm or more, the box can be fixed in the wall without the mounting bracket

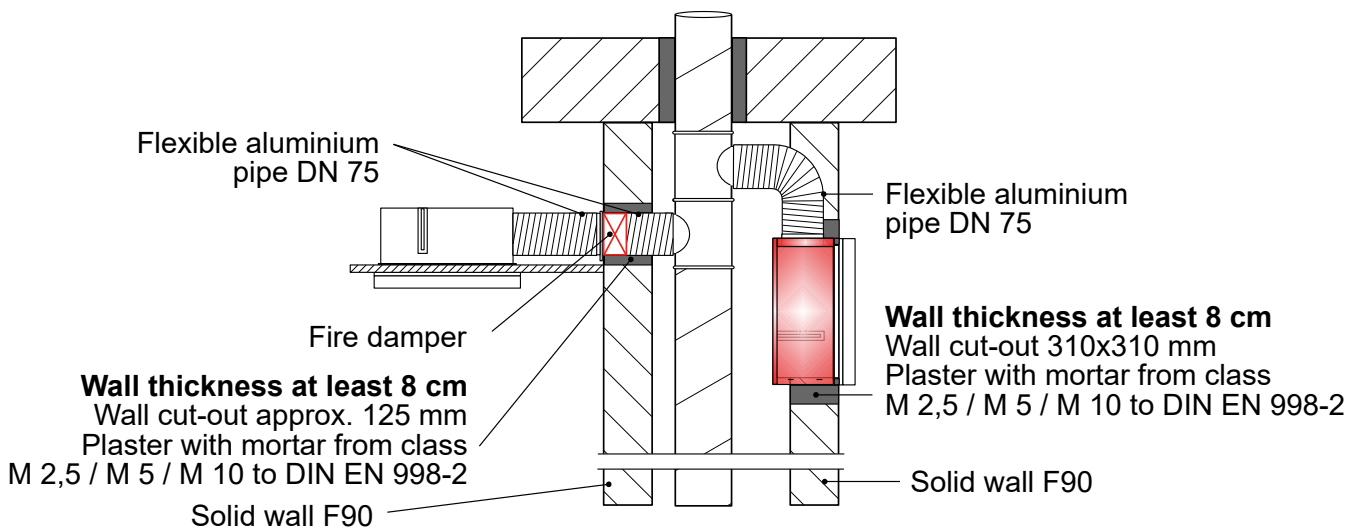

Installation in bathrooms and toilets in buildings with fire resistance requirements, in the fire-resistant shaft or in the ventilation duct with 230 mm height offset

Single-room ventilation unit from the "VARIO II" series /
Example installations for unit types UB and UB-H with height offset

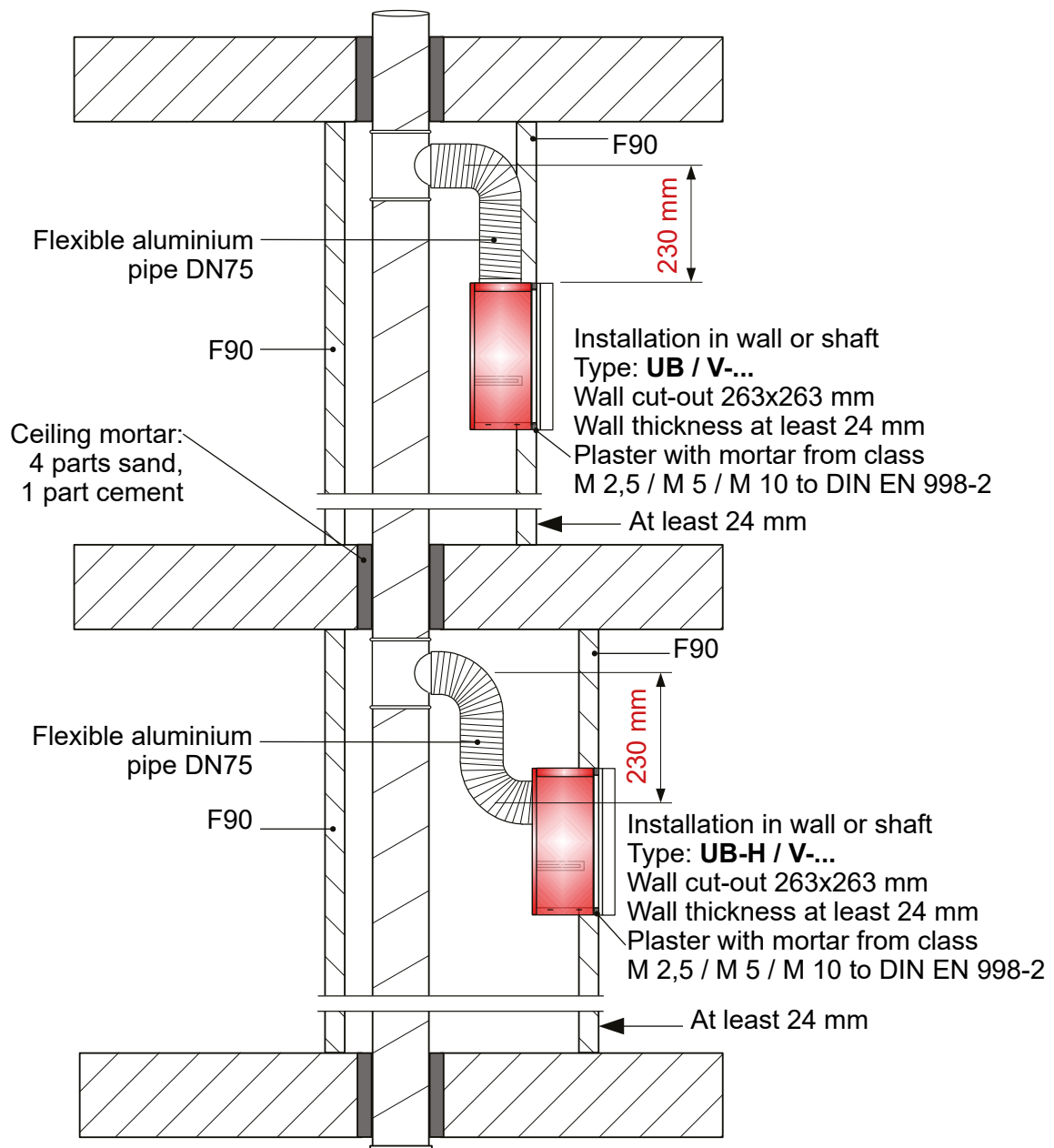

Installation in kitchens, kitchenettes, bathrooms and toilets in buildings with fire resistance requirements, inside and outside the fire-resistant shaft or ventilation duct

Single-room ventilation unit from the "VARIO II" series / Example installations for unit types U with fire damper provided by the customer, **UBK** and **UBK-H** with integrated fire damper

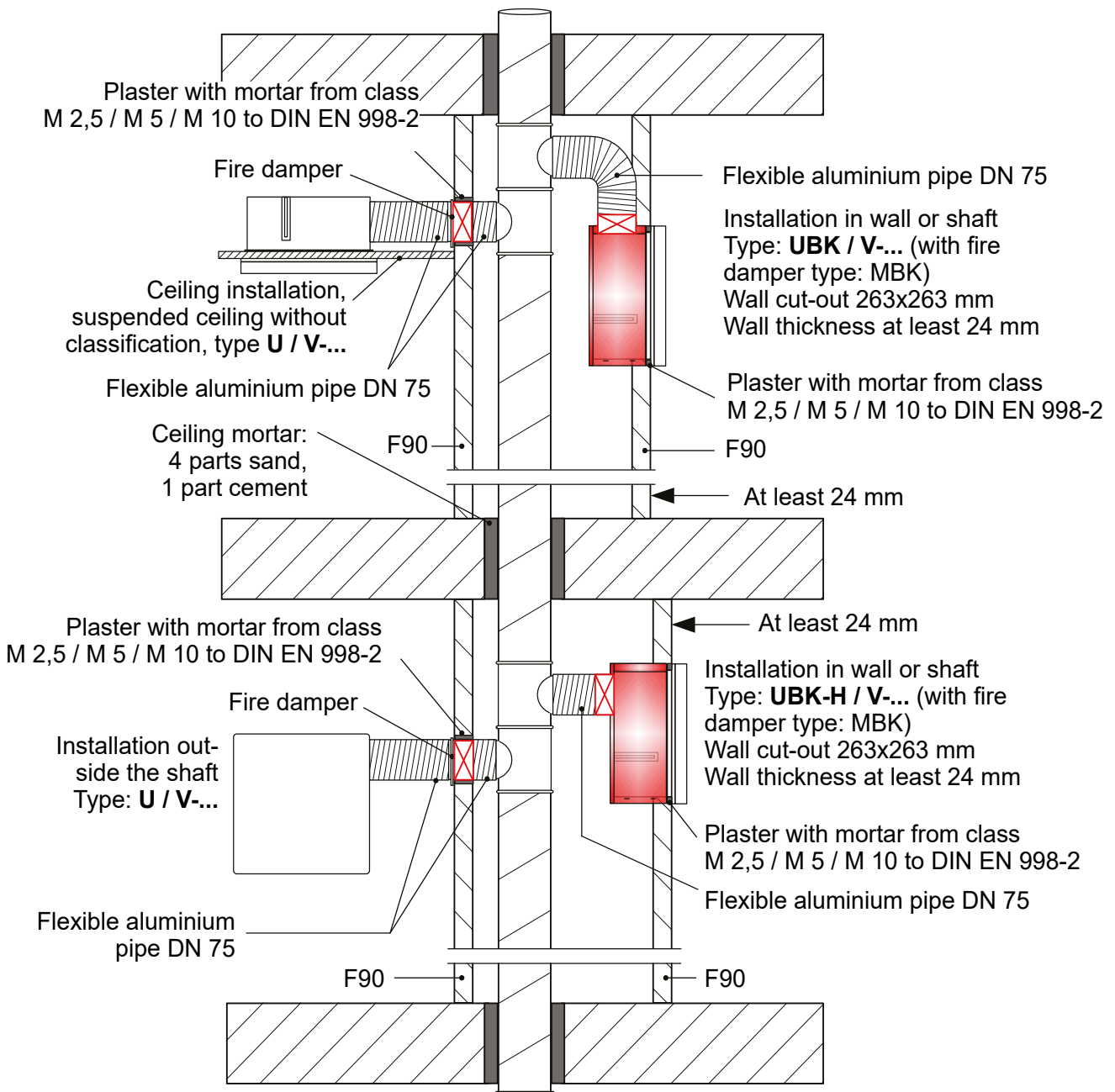

Installation in bathrooms and toilets in buildings with fire resistance requirements, outside the fire-resistant shaft or ventilation duct with 230 mm height offset

Single-room ventilation unit from the "VARIO II" series /
 Example installations for unit types A, U and U-H with height offset

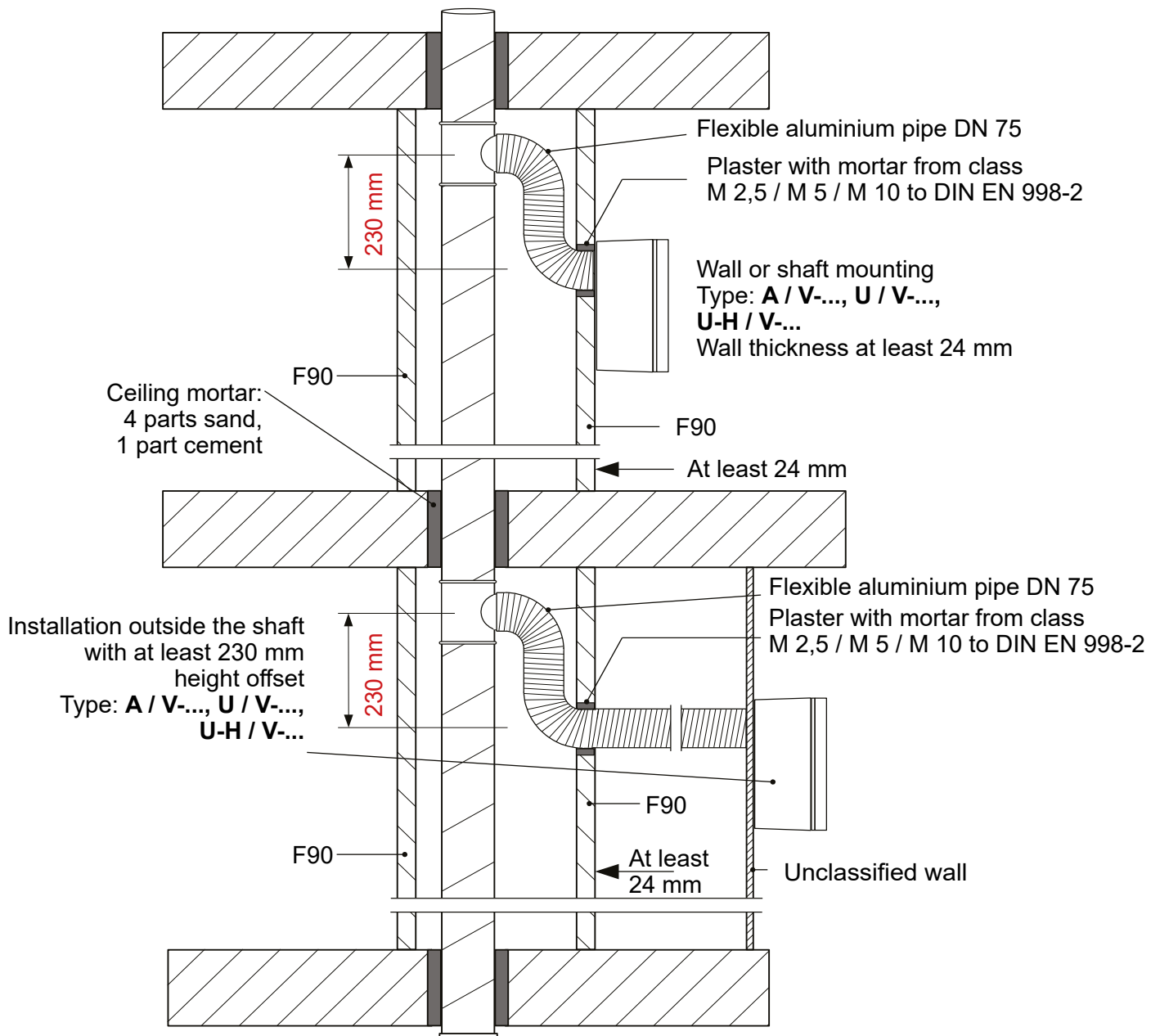

Installation in kitchens, kitchenettes, bathrooms and toilets in buildings with fire resistance requirements, outside the fire-resistant shaft or ventilation duct

Single-room ventilation unit from the “VARIO II” series /
Example installations for unit type AK with integrated fire damper

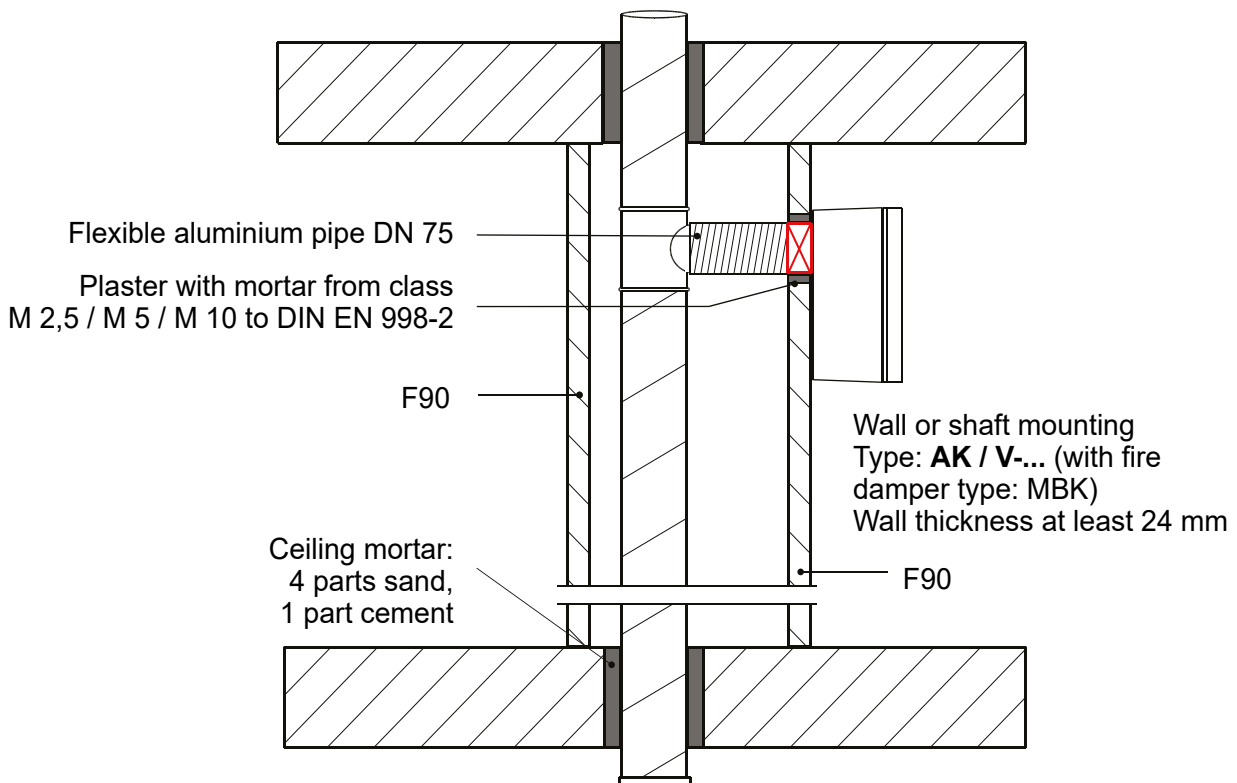

Space for your notes

A large grid of graph paper for taking notes, consisting of 20 columns and 30 rows of small squares.

Space for your notes

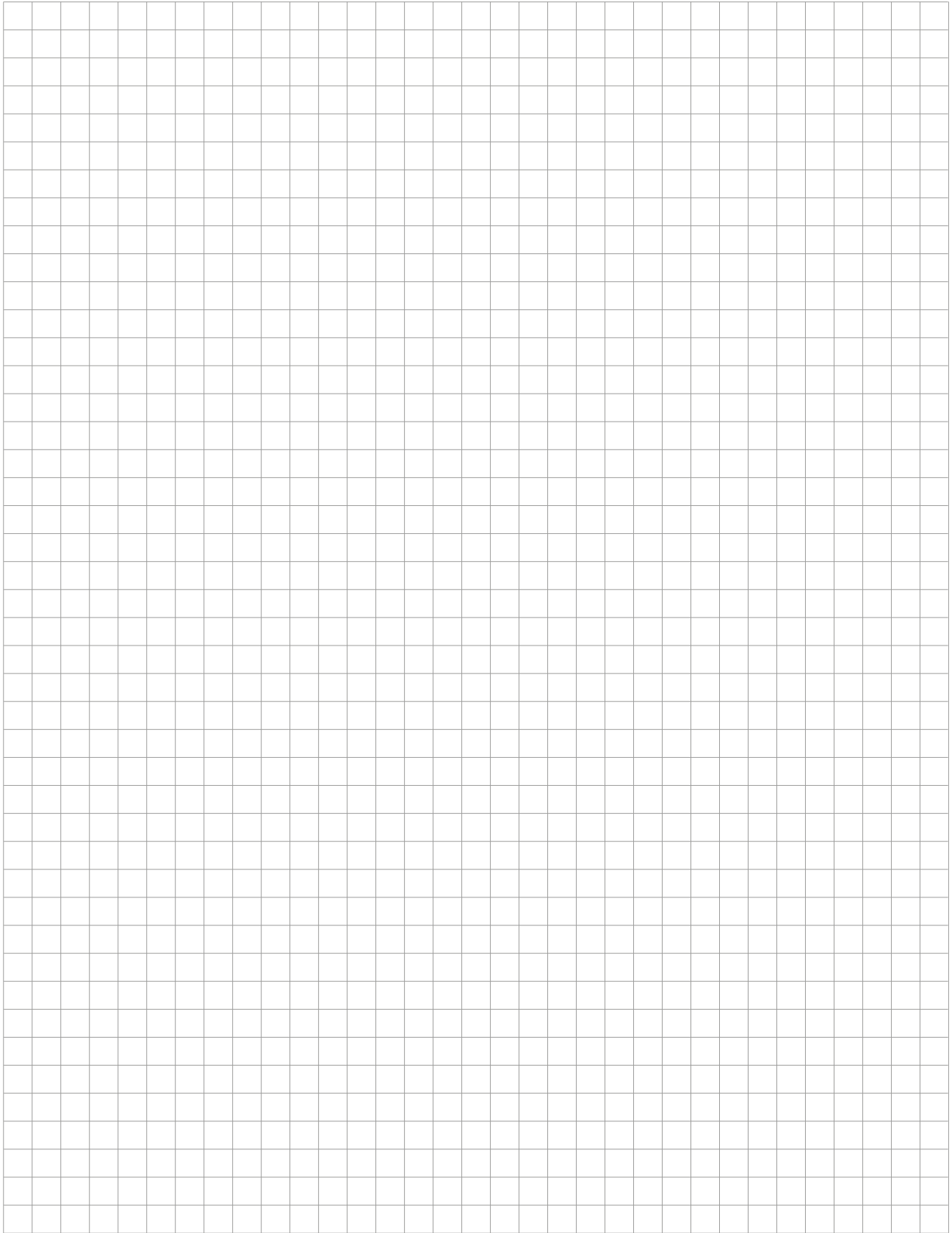

Space for your notes

A large grid of 25 columns and 35 rows for taking notes. The grid is composed of small squares, suitable for detailed notes or calculations.

Space for your notes

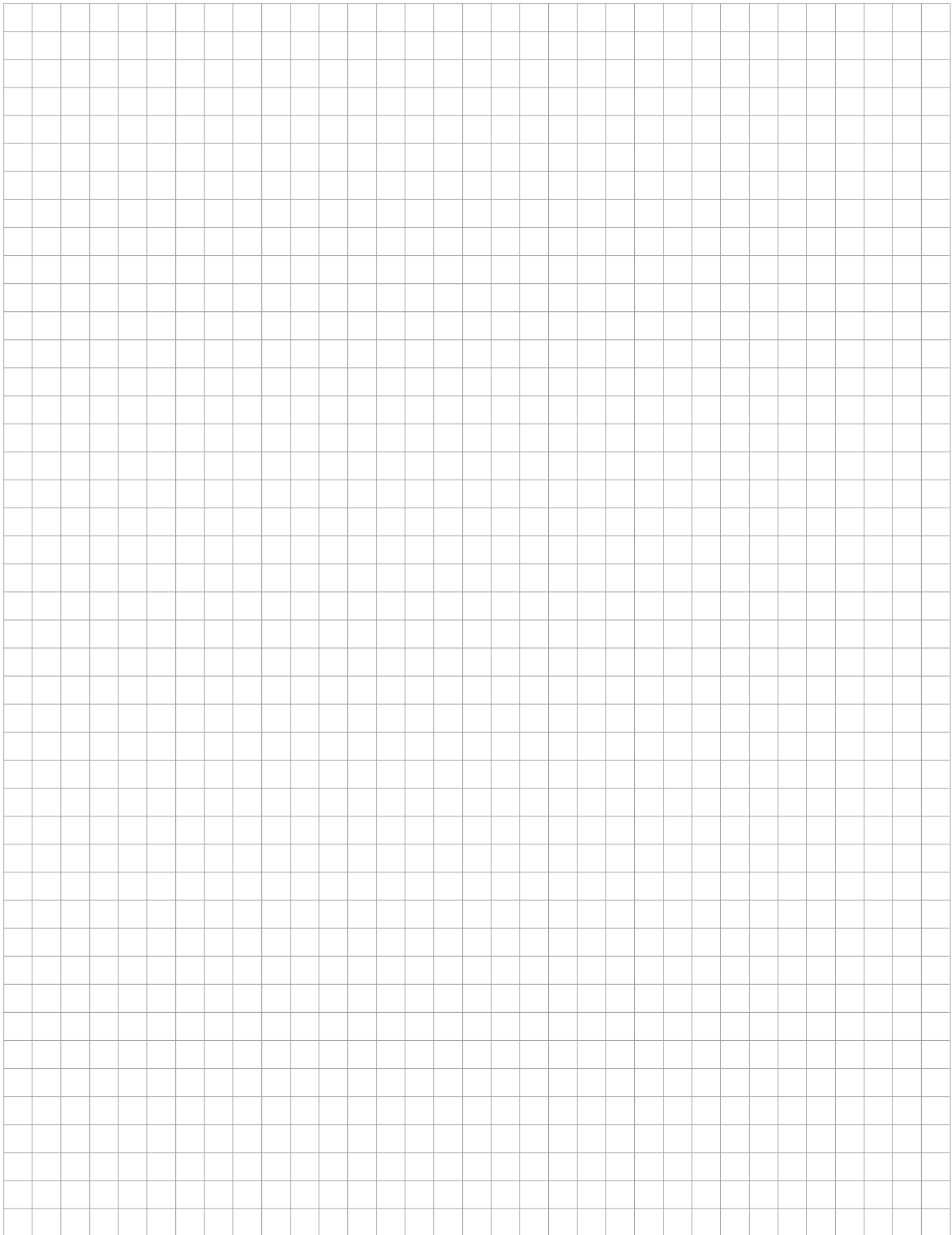

Ventilation the
RIGHT way!

SANITARY FACILITIES IN THE INTERIOR
Mould prevention by ventilation



SANITARY FACILITIES
Ventilation to remove moisture

SINGLE-FAMILY HOME
Ventilation of bathrooms/toilets



Distribution partner:

Meltem is one of Europe's leading manufacturers of decentralised ventilation units. Meltem creates innovative solutions to provide fresh and clean air so that you can feel happy and healthy at home or in your professional environment.

For planning and installation, please read our installation manuals which are available on our website. All information in this brochure is supplied without guarantee. Subject to technical modifications and misprints.

Meltem
Lüftungsgeräte GmbH & Co. KG

Am Hartholz 4 · D-82239 Alling
Phone: +49 8141 36 90-0
Fax: +49 8141 36 90-60

info@meltem.com · www.meltem.com

